



Theses and Dissertations

2019-04-01

A Discovery of Social Impact Categories for the Sustainable Design of Engineered Products and Their Consideration by Industry Professionals

Andrew Taylor Pack
Brigham Young University

Follow this and additional works at: <https://scholarsarchive.byu.edu/etd>

BYU ScholarsArchive Citation

Pack, Andrew Taylor, "A Discovery of Social Impact Categories for the Sustainable Design of Engineered Products and Their Consideration by Industry Professionals" (2019). *Theses and Dissertations*. 7368. <https://scholarsarchive.byu.edu/etd/7368>

This Thesis is brought to you for free and open access by BYU ScholarsArchive. It has been accepted for inclusion in Theses and Dissertations by an authorized administrator of BYU ScholarsArchive. For more information, please contact scholarsarchive@byu.edu, ellen_amatangelo@byu.edu.

A Discovery of Social Impact Categories for the Sustainable Design of Engineered
Products and Their Consideration by Industry Professionals

Andrew Taylor Pack

A thesis submitted to the faculty of
Brigham Young University
in partial fulfillment of the requirements for the degree of

Master of Science

Christopher A. Mattson, Chair
Spencer P. Magleby
John L. Salmon

Department of Mechanical Engineering
Brigham Young University

Copyright © 2019 Andrew Taylor Pack

All Rights Reserved

ABSTRACT

A Discovery of Social Impact Categories for the Sustainable Design of Engineered Products and Their Consideration by Industry Professionals

Andrew Taylor Pack
Department of Mechanical Engineering, BYU
Master of Science

Sustainable design is often practiced and assessed through the consideration of three essential areas: economic sustainability, environmental sustainability, and social sustainability. For even the simplest of products, the complexities of these three areas and their tradeoffs cause decision-making transparency to be lost in most practical situations. Additionally, the models and tools available to consider social sustainability are severely underdeveloped. This thesis is separated into three parts: 1) a design tool to consider all three aspects of sustainability simultaneously, 2) a literature survey to characterize social impact as it relates to products, and 3) interviews with engineering professionals regarding how social impact is currently considered in product design in industry.

The existing field of multiobjective optimization offers a natural framework to define and explore a given design space. In chapter 2 of this thesis, a method for defining a product's sustainability space (defined by economic, environmental, and social sustainability objectives) is outlined and used to explore the tradeoffs within the space, thus offering both the design team and the decision makers a means of better understanding the sustainability tradeoffs. This chapter concludes that sustainable product development can indeed benefit from tradeoff characterization using multiobjective optimization techniques – even when using only basic models of sustainability. Interestingly, the unique characteristics of the three essential sustainable development areas lead to an alternative view of some traditional multiobjective optimization concepts, such as weak Pareto optimality. The sustainable redesign of a machine to drill boreholes for water wells is presented as a practical example for method demonstration and discussion. In these efforts it became apparent that the tools for considering social impact were lacking and needed to be further developed.

While efforts have been made to identify social impacts, academics, and practitioners still disagree on which phenomena should be included, and few have focused on the impacts of products specifically compared with programs, policies, or other projects. The primary contribution of chapter 3 of this thesis is to integrate scholarship from a wide array of social science and engineering disciplines that categorizes the social phenomena that are affected by products. Specifically, we identify social impacts and processes including population change, family, gender, education, stratification, employment, health and well-being, human rights, networks and communication, conflict and crime, and cultural identity/heritage. These categories are important because they can be used to inform academics and practitioners alike who are interested in creating products that generate positive social benefits for users.

Though academic research for identifying and considering the social impact of products is emerging, additional insights can be gained from engineers who design products every day. Chapter 4 explores current practices in industry used by design engineers to consider the social impact

of products. 46 individuals from 34 different companies were interviewed to discover what disconnects exist between academia and industry when considering a product's social impact. These interviews were also used to discover how social impact might be considered in a design setting moving forward. This is not a study to find 'the state of the art', but considers the average engineering professional's work to design products in various industries. Social impact assessments (SIA) and social life cycle assessments (SLCA) are two of the most common processes discussed in the literature to evaluate social impact, both generally and in products. Interestingly, these processes did not arise in any discussion in interviews despite respondents affirming that they do consider social impact in product design. Processes used to predict social impact, rather than simply evaluate, were discussed by the respondents and tended to be developed within the company and often related to industry imposed government regulations.

The combined work reported in this thesis is a significant step forward in being able to handle the unwieldy nature of social impact in product design in the larger context of sustainability. Not only do these efforts provide a basis upon which future tools can be developed, they are also immediately useful in providing a basic framework upon which to consider the full spectrum of social impact of products during design.

Keywords: Andrew Taylor Pack, social impact, product design, sustainability, sustainable product design

ACKNOWLEDGMENTS

This work would not have been possible without the countless hours of advice and mentorship by Dr. Chris Mattson. Other individuals working with Dr. Mattson and worth acknowledging for their influence and assistance in my research are Dr. Spencer Magleby, Dr. John Salmon, and members of the Mechanical Design Collective at Brigham Young University.

Much of this work was, and continues to be, the effort of collaborations between mechanical engineering and sociology. As such, I would like to acknowledge the significant contributions provided by Dr. Eric Dahlin, Meagan Rainock, Dallin Everett and Emma Rose Phipps, without whom much of this research would not have been possible.

Lastly, I would like to thank my wife for her love and support through these many years of education and research. Words cannot express the amount of support and motivation she provided.

TABLE OF CONTENTS

LIST OF TABLES	vii
LIST OF FIGURES	viii
NOMENCLATURE	ix
Chapter 1 Introduction	1
1.1 Sustainability	1
1.2 Product Social Impact in Literature	2
1.3 Product Social Impact in Industry	3
1.4 Motivation	4
Chapter 2 Using a Product's Sustainability Space as a Design Exploration Tool	5
2.1 Introduction	5
2.2 A Review of Previous Work	7
2.2.1 Sustainable Product Development	7
2.2.2 Multiobjective Optimization	9
2.2.3 Optimization-based Sustainable Product Development	10
2.2.4 Observations from the Literature Survey	11
2.3 Tradeoff Exploration Using a Product's Sustainability Space	12
2.3.1 Step 1: Identify Pertinent Sustainability Issues	14
2.3.2 Step 2: Link Sustainability Issues to Independent Parameters	15
2.3.3 Step 3: Aggregate Independent and Dependent Parameters into Single Measures of Economic, Environmental, and Social Sustainability	16
2.3.4 Step 4: Find the Sustainability Space	17
2.3.5 Step 5: Explore the Sustainability Space and Choose a Specific Sustainable Design	18
2.4 Example: Village Drill	19
2.4.1 Example: Step 1 (Identify Sustainability Issues)	21
2.4.2 Example: Step 2 (Link Issues to Parameters)	22
2.4.3 Example: Step 3 (Aggregate Parameters)	34
2.4.4 Example: Step 4 (Find Sustainability Space)	36
2.4.5 Example: Step 5 (Explore Sustainability Space)	38
2.4.6 Example: Discussion	41
2.5 Concluding Remarks	42
Chapter 3 The Social Impacts of Products: A Review	45
3.1 Introduction	45
3.2 Existing Frameworks	46
3.3 Population Change	51
3.4 Family	51
3.5 Gender	53

3.6	Education	54
3.7	Paid Work	55
3.8	Stratification	55
3.9	Health and Safety	56
3.10	Human Rights	57
3.11	Social Networks and Communication	58
3.12	Conflict and Crime	58
3.13	Cultural Heritage and Identity	59
3.14	Conclusion	60
Chapter 4	Social Impact in Product Design, An Exploration of Current Industry Practices	63
4.1	Introduction	63
4.1.1	Overview of Sustainability	63
4.1.2	Assessing the Social Impact of Products	64
4.2	Literature Review	64
4.2.1	Engineering Design & Social Impact in Academia	65
4.2.2	Social Impact in Industry	66
4.2.3	Observations from the Literature Review	66
4.3	Methodology	67
4.3.1	Research Design	67
4.3.2	Procedure	70
4.4	Results & Discussion	71
4.4.1	Research Topic 1	71
4.4.2	Research Topic 2	72
4.4.3	Research Topic 3	76
4.4.4	Research Topic 4	77
4.4.5	Additional Results: General Themes	79
4.5	Conclusion	81
Chapter 5	Conclusion	82
5.1	Sustainability Design Space	82
5.2	Literature Survey	83
5.3	Industry Interviews	84
5.4	Final Observations	85
REFERENCES	87
Appendix A	Interview Guide for Industry Professionals	103
A.1	Interview Guide	103
A.2	Research Questions	103

LIST OF TABLES

2.1	Village Drill Design Constraints	36
3.1	Social Impact Categories	50
A.1	Social Impact Categories for Industry Interviews	105

LIST OF FIGURES

2.1	Example Sustainability Space	6
2.2	Example of General Pareto Optimality	9
2.3	Example of Weak Pareto Optimality	19
2.4	Village Drill Concept	21
2.5	Village Drill Independent Parameters	23
2.6	Basic Relationships for Wheel Diameter	24
2.7	Spoke End Cap Design	32
2.8	Injury Parameter Relationships	33
2.9	Village Drill Sustainability Design Space, 3D	37
2.10	Village Drill Sustainability Design Space, 2D Snapshots	38
2.11	Computer Generated Drill Designs	40
4.1	Participant Demographic Information	69
4.2	Aggregated Social Impact Considerations	73
4.3	Segmented Social Impact Considerations	74
4.4	Social Impact Consideration Standard Deviation	75
4.5	Social Impact Consideration Standard Deviation, Health & Safety Data Removed	76
4.6	Measurability of Social Impact Processes	77
4.7	Social Impact Process Types	79

NOMENCLATURE

Village Drill Parameters

l_i	Length for a given piece in the drill assembly
w_i	Width for a given piece in the drill assembly
h_i	Height for a given piece in the drill assembly
t_i	Thickness for a given piece in the drill assembly
A_i	Cross sectional area for a given piece in the drill assembly
m_i	Mass for a given piece in the drill assembly
m_t	Total mass of the drill
θ	Angle of cantilever beam
n	Number of drill wheel spokes
l_d	Maximum depth capabilities of the drill
d_i	Diameter of the drill pipe
d_w	Diameter of the drill wheel
ρ	Density of selected material
C_{tot}	Total cost of the drill to produce
C_{mat}	Cost of material to produce the drill
C_{wld}	Cost of welding drill in assembly
C_{hdwr}	Cost of nuts, bolts, washers and other hardware in the drill
C_i	Cost (per gram) of the material selected for a given piece in the drill assembly
D_{wld}	Welding distance required
$C_{wld,rate}$	Cost of welding per hour
R_{wld}	Weld rate in mm/hr
P	Selling price of the drill
ϵ_{mfg}	Total emissions to produce drill
$E_{f,i}$	Emissions required to produce steel
$E_{f,wld}$	Emissions required to weld
$p_{w,i}$	Welding required for a given piece in the drill assembly
ϵ_{shp}	Emissions required to ship the drill
D_{shp}	Distance required to ship (km)
$E_{f,shp}$	Emissions required to ship the drill one kilometer
ϵ_{∞}	Total emissions of the drill over its useful life
$E_{f,pm}$	Emissions produced from running the pump with the drill
n_{bpm}	Number of boreholes produced per drill
f	Fuel required to run the pump for one borehole
N_{ppl}	Number of people served water
t_{pb}	Average time to drill one borehole
C_{op}	Cost to produce one borehole
f_{mud}	Fraction of the time spent running the drill in soft soil
f_{rock}	Fraction of the time spent running the drill through rock
R_c	Cut rate per rotation of the drill wheel
n_{stop}	Number of stops required during drilling
t_{stop}	Time required per stop
t_{setup}	Time required to setup of the drill before use

C_{op}	Cost for operation
C_{fuel}	Cost of fuel
W_{labor}	Labor rate per hour
N_{jobs}	Number of jobs provided by the drill
n_{op}	Number of operators required to spin the drill
I_{stop}	Potential for injury during stopped time
p_i	Probability of injury occurring from a given hazard
S_i	Severity of injury that may occur from a given hazard
t_{stop}	Time required per stop
E_p	Binary value to represent the presence or absence of the end plate
F_{of}	Force per person required to operate the drill
t_{stop}	Time required per stop
S_{eco}	Economic sustainability score
S_{env}	Environmental sustainability score
S_{soc}	Social sustainability score

CHAPTER 1. INTRODUCTION

1.1 Sustainability

Sustainable development's goal, as defined by the Brundtland report in 1987 [1], is to meet the needs of today without sacrifice the ability of future generations to meet their needs as well. This important goal has recently become one of the most popular goals for many organizations [2]. In fact, the United Nations Environmental Programme (UNEP) has designated sustainability as the main goal for the future development of human kind [3]. We are fast approaching a point where considering sustainability will no longer be optional, but will be a requirement imposed by stakeholders or legislative policies [4].

A common way to consider sustainability is to divide it into three categories; economic, environmental and social sustainability [5]. This is frequently referred to as the triple bottom line [6, 7], or the three pillars of sustainability [8]. These impact areas can be manifest in community or governmental programs, business practices, engineered products and processes, and more. The scope of this thesis is to consider sustainable development as it relates to engineered products and their development.

Economic sustainability – often tied to profitability – has long been a regularly considered area of impact in product development, while environmental and social sustainability have not [9]. However, growing awareness of contemporary issues such as resource depletion [10], the circular economy [11], and corporate social responsibility [12] has caused various organizations to consider becoming more fully sustainable in their products, services, or operating practices, while maintaining desirable economic performance.

To support decision makers and their organization's desire to become more sustainable, chapter 2 presents an approach for exploring design tradeoffs as they relate to sustainability. Specifically, chapter 2 characterizes the *Sustainability Space*, which is a set of design alternatives positioned within a three-dimensional geometric space defined by economic, environmental,

and social sustainability objectives. Measures and models to help a design engineer consider both the economic and environmental impacts of their products were readily found in literature while developing metrics for social impacts had to be rigorously developed specifically for chapter 2. In doing this, it became apparent that models and measures for social sustainability were lacking.

To more fully understand the field of social impact as it relates to products, a multi-view research approach was adopted. Three separate research studies were conducted in order to view this gain a valuable perspective from each study. These three studies focused on: 1) a literature survey, which aggregates what is found in academic literature about product social impacts, 2) a product survey, which seeks to understand what social impacts a product may be perceived to have and what are the relationships between those impacts, and 3) an industry survey, which works to discover how industry professionals working in product development currently consider the social impact of their designs.

These three approaches create a foundation for future work in the area of social impact. Already there are efforts to develop new metrics for product social impact [13] which can lead to better tools for use in sustainable product design. While three elements make up this multi-view research approach, only the literature survey and industry survey (items 1 & 2) are reported here in chapters 3 and 4, respectively.

1.2 Product Social Impact in Literature

Though exceptions exist, social impacts have not yet been the focus of significant research efforts or included in the calculus utilized by engineers to evaluate product design features. Yet, the concept of social impacts – the influence of a product “on the day-to-day quality of life of persons” [14] – has a long-standing tradition in the mechanical and manufacturing engineering professions, whose codes of ethics emphasize holding “paramount the safety, health and welfare of the public” [15] and considering “the consequences of [our engineering] work and societal issues pertinent to it.” [16] Despite the genuine and near-universal acceptance of these sentiments, most practitioners do not commonly characterize the social impact of products beyond the basic principles of mechanical and structural safety. Therefore, understanding the social impacts of design frequently remains out of sight and reach of those who create and manufacture products.

The academic literature devoted to social impacts of products lags behind the attention given to the topic by practitioners in the nonprofit sector. Exceptions include Vanclay [17], Epstein and Yuthas [18], and Fontes et al. [19] who note that the relevance of particular social impacts often depend on the local context or community. While efforts often result in lists of social impacts that scholars and practitioners would do well to consider and represent a useful and growing body of literature, their grounding in empirical research is often limited. Many of these sources that offer lists of social impacts have been generated from the authors' experience or influenced by the authors' "prejudices and biases" [17]. Chapter 3 is a step toward addressing the issue of biased tools by integrating a wide range of studies in the social science and engineering literatures with the intent to better inform our conception of products' social impacts. The result of this effort is the characterization of 11 product social impacts categories, which will be used in chapter 4 as well.

1.3 Product Social Impact in Industry

Engineers stand in position to pioneer best practices in accounting for a holistic view of sustainability, where "Sustainability Engineering is poised to propel the industry into a future that combines permanence, profitability, as well as livability" [20]. As engineers design with all aspects of sustainability in mind, they are likely to create effective and desirable products while also influencing the world's economic standing, environmental state, and social well-being. Though designing engineered products and systems from a social well-being perspective is an emerging topic *in literature*, chapter 4 seeks to understand to what extent designing for social impact is found *in industry*, among practicing engineers.

To be clear, the goal is *not* to review the state of the art in social impact design, but to simply understand the degree to which common engineers currently consider the social implications of their designs. While social sustainability research may be lagging behind economic and environmental sustainability, current practices within the engineering field can prove that social sustainability is being increasingly accounted for.

1.4 Motivation

As previously stated, the eventual goal is to make all aspects of sustainability equally practical to design for. Currently, the tools for considering a product's social impact are underdeveloped. This thesis contains three parts, first, a tool which characterizes the sustainability space and assists an engineer to understand the tradeoffs between the three categories of sustainability. It was in this effort that it became apparent for the need for better tools in social sustainability. This leads to the final two sections which are a literature survey and industry survey to gain new insights into social impact as it relates to products. Through this work, engineers and product designers can open their minds to potentially new social impacts never considered before and work to develop products that are equally socially sustainable as they are economically and environmentally sustainable. Additionally, new tools can be developed to make designing for social impact more accessible and practical. In this way, the research found herein can be used both as a starting point for engineers to consider social impact and as a foundation for new tools for social impact design to be built upon.

CHAPTER 2. USING A PRODUCT'S SUSTAINABILITY SPACE AS A DESIGN EXPLORATION TOOL

2.1 Introduction

Regardless of whether it is explicitly considered or not, engineered products generally have three impact areas tethered to them. They are economic impact, environmental impact, and social impact. These three areas are the basis for sustainable design as introduced by Elkington [21], and adopted by others [5, 22, 23]. Sustainable design seeks to develop products that have maximum positive impact and/or minimum negative impact on the economy, environment, and society [1, 9].

Economic sustainability – often tied to profitability – has long been a regularly considered area of impact in product development, while environmental and social sustainability [9] have not. However, growing awareness of contemporary issues such as resource depletion [10], the circular economy [11], and corporate social responsibility [12] has caused various organizations to consider becoming more fully sustainable in their products, services, or operating practices, while maintaining desirable economic performance.

As a way of injecting a sustainable culture into an organization, some have created a position for sustainability officers [8] and have tried to implement *sustainable thinking* into their product development process. While this has potentially raised awareness of sustainability at all levels of the organization, it has not changed the fact that the tradeoffs between economic, environmental, and social sustainability can be obscured and not intuitively resolvable by the organization's general body of decision makers [24]. Unfortunately, this condition often relegates sustainable design to a philosophy that many agree with in principle but find difficult to execute [25, 26].

To support decision makers and their organization's desire to become more sustainable, this paper presents an approach for exploring design tradeoffs as they relate to sustainability. Specifically this paper characterizes the *Sustainability Space*, which is a set of design alternatives positioned within a three-dimensional geometric space defined by economic, environmental, and

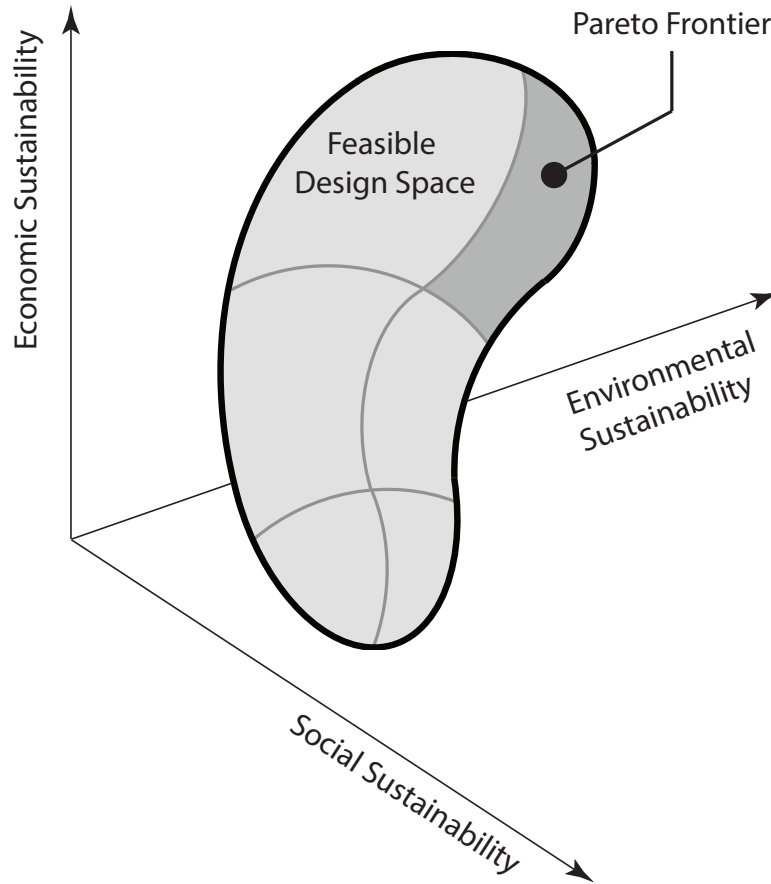

Figure 2.1: The sustainability space, defined by the three pillars of sustainable design; economic, environmental, and social sustainability. The shape within the space, represents the set of feasible design alternatives, and the region shaded darkly represents the optimal tradeoff surface, or more formally the Pareto frontier. We seek Pareto solutions because they represent the best that can be feasibly achieved.

social sustainability objectives, as illustrated in Fig. 2.1. While potentially useful in all stages of the product development process, the framework presented here is specifically for the redesign of an existing product. As such, it is assumed that enough design information is available to construct parametric models of product performance and sustainability – which is not an unrealistic assumption for companies that have become well-established in a particular industry. From these models, however basic or rudimentary they may be, a set of design alternatives can be generated by changing the models’ parameter values and the sustainability space can be found.

To be clear, the definitions used throughout this paper for environmental impact and social impact are: the effect an engineered product has on the natural world, and the effect that an engineered product has on the day-to-day quality of life of persons or communities, respectively.

For the purpose of this paper, the latter definition excludes such issues as manufacturing workers' rights and community cohesion in the location of the production facility, as these issues are less likely to be influenced by product design decisions, and more likely to be influenced by supply chain decisions.

We note that this paper does not attempt to contribute a new optimization technique to the literature, but instead uses existing methods found in multi-objective optimization literature to characterize and navigate the sustainability space. These techniques have not been presented in the literature as a way to find the sustainable design space, but doing so can provide benefit to product design teams seeking a quantitative technique to consider the design space created by the three top-level objectives of sustainability. Along with building the design space, we also provide guidelines for converging on a final sustainable design.

Before presenting the approach, we briefly review pertinent related literature upon which the present paper is built (Section 2.2). In Section 2.3, five steps for finding and exploring the sustainability space are presented. These steps are demonstrated in Section 2.4 as a machine for drilling for water wells is redesigned for greater sustainability. Section 2.5 provides our main conclusions from the research and delineates its limitations.

2.2 A Review of Previous Work

In this section, we briefly review literature in the areas of sustainable product development, multi-objective optimization, and the way these two areas have mingled in the literature.

2.2.1 Sustainable Product Development

Definitions of sustainability vary widely [27] however the Brundtland report defines sustainable development as development that meets the needs of the present without compromising the ability of future generations to meet their own needs [1]. Many have interpreted this to include economic, environmental, and social impacts [5, 22, 23]. This paper works in harmony with these definitions and specifically looks at the impact a product will have relative to the three pillars of sustainability.

Although not always considered by design teams, engineered products often have an impact economically, environmentally, and socially [28]. Considering this *triple bottom line* – as it is often referred to – we can reasonably assert that economic sustainability (when characterized by profitability) has always been a part of product development. In contrast, the same cannot be said for environmental sustainability, which emerged on the agenda in the late 1990s within the product development sector [29–32]. It was at this time that life-cycle thinking, which encourages environmental considerations at every stage of the product life-cycle (from materials extraction to final disposal at the end of life), grew in popularity and it was recognized that a product’s environmental impact is most effectively influenced when considered in the early stages of the product development process [33, 34]. The literature now contains a wide range of methods and tools to support life-cycle thinking including LiDS wheel [29], Eco Indicator 99 [35], the LEED Rating System [36], and more [37, 38].

The one branch of the triple bottom line that has yet to receive much attention in the product development literature is social justice [39, 40]. Nevertheless, the products developed by organizations *do* impact society [9, 41]. Unfortunately, social aspects are not often integrated into product development processes and only a few leading-edge companies have progressed beyond ecodesign [42, 43]. There has been, however, a growing interest in the use of *design* by foundations and non-governmental organizations (NGOs) to assist with social change, particularly in relation to the challenges of resource-poor countries [44, 45]. While sustainable design is emerging as an important approach for industry to adopt, research has shown that current sustainable design approaches tend to focus on only a small number of environmental issues such as recyclability, material selection, and energy consumption. Consequently these have limited ability to result in large-scale sustainability improvements [46].

There has however been some progress in considering all three pillars together. For example, Buchert et. al. developed an early stage method to simultaneously consider all three pillars of sustainability to assist in choosing material and manufacturing process [5]. And others have successfully applied a full sustainable evaluation for a specific product [47].

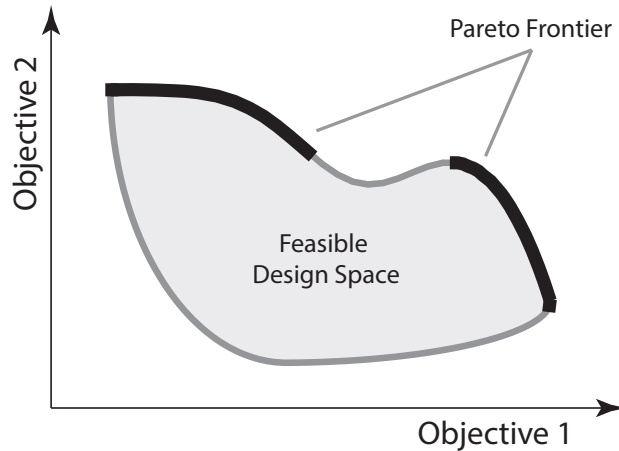

Figure 2.2: The general concept of Pareto optimality for two objectives being maximized. The gray shaded space represents feasible solution space and the dark curve represents the set of Pareto solutions (non-dominated solutions).

2.2.2 Multiobjective Optimization

As organizations seek sustainable design solutions, there will inevitably be tradeoffs between economic, environmental, and social sustainability. The field of multiobjective optimization offers existing tools and theories to support the management of tradeoffs [48–50].

Multiobjective optimization is fundamentally different than single objective optimization in that it must consider the tradeoffs between competing objectives before a final single solution can be chosen. As such, multiobjective optimization problems generally result a set of design alternatives that are non-dominated mathematically [51]. These are called Pareto solutions, the set of which comprises the Pareto frontier as shown in Fig. 2.2 where both objectives are maximized. Pareto solutions are defined as non-dominated because there are no other feasible designs for which *all* objectives are the same or better.

There are two basic optimization strategies for solving multiobjective design problems. The first strategy takes the multiple objectives and combines them into one objective and from that point treats the problem as single objective. The second strategy is to generate a set of design alternatives – all belonging to the Pareto frontier – from which the decision-making body chooses the most desirable one. Neither method is without criticism [52–55].

Regardless of what optimization strategy is used, the design will need to be represented mathematically in some form. Various design tools seek to simplify a product or system and

represent the design in alternate formats. Tools such as matrix-based methods and axiomatic design [56] characterize functions and requirements allowing the designer to easily find critical parameters or features of a systems. Even within matrix based methods there are various ways to characterize a product or system. Other tools, such as Characteristics Property Model and Property Driven design decomposes the design and considers either the structure of the product or the functions on an individual basis [57,58].

2.2.3 Optimization-based Sustainable Product Development

Various publications describe the search for desirable sustainable solutions. Some are based on traditional single objective optimization techniques [59], others are based on multiobjective optimization techniques [60–64], and some are not based on numerical optimization at all [65].

Despite the use of optimization techniques for sustainable design, the multiobjective characterization of the three essential areas of sustainable design is surprisingly missing from the literature. That is to say, we have found no paper that promotes the value in identifying the sustainability space, shows how to identify it, nor how to navigate through it.

A valuable review of multi-criteria decision making for sustainable design is presented by Pohekar and Ramachandran [66]. This review not only examines multiobjective optimization techniques, it also reviews a variety of approaches for aggregating objectives into a single objective. This is appropriate as the overwhelming trend in the papers reviewed by Pohekar and Ramachandran is to aggregate all sustainability issues into one measure that is optimized. In nearly all of the cases reviewed, economic sustainability is one of the issues considered, while in many cases it is considered only in the context of one other sustainability area, be it environmental or social. It's important to recognize that while the tradeoff conditions are considered by the optimizer (computer) when the objectives are aggregated, they are not visible, evaluable, or explorable to the design team or decision makers. While the review carried out by Pohekar is over a decade old, it does provide valuable insight into many techniques still used today.

More recently, a noticeable quantity of work has been done on optimization-based environmental sustainability. A variety of topic areas are present in the literature including tradeoff resolution between performance and environmental impact [67, 68]; multiobjective optimization in ecodesign [60]; multiobjective considerations of environmental impact [69]; wind farm opti-

mization [59]; the search for sustainable systems based on a multi-domain optimization formulation [70]; and the multiobjective evaluation of economic and environmental issues using evolutionary algorithms [62, 71]. Some provide an explicit Pareto-based approach; Shahi et al., do this for the sustainable development of hybrid vehicles [61]. Others provide a strong link to life-cycle analysis (LCA) [72].

An additional consideration relevant to sustainable design is the role that governmental regulations have on the final design. Current literature has shown that optimization algorithms may successfully include government policies that affect the design space [73, 74]. This research shows great potential in combining policy regarding the environment with other design models to predict design changes based on these policies. If desired, these methods could be easily combined with the method presented herein to get a more complete evaluation of product sustainability.

Despite the large quantity of recent work in this area, few have attempted to include social issues in the optimization. Rossing et al. provide some guidelines for dealing with socio-economic constraints [75]. You et al. is one of the few papers that explicitly considers economic, environmental, and social objectives [63]. Unfortunately, they don't provide a discussion about the sustainability space, how to find it, or what it means to sustainable product development as a whole. Matar et al. [25] explores project life-cycle phases, project execution entities, and sustainability performance parameters, but like You et al., [63] does not provide insight regarding the sustainability space as defined by the triple bottom line.

2.2.4 Observations from the Literature Survey

A sizable portion of the literature of the sustainable development literature clearly advocates a triple-bottom-line approach to sustainability (economic, environmental, social sustainability) [25, 60–64, 69, 75]. Because these three elements are intrinsically linked, decisions regarding any one of them is best made in the context of all three elements together [25, 63]. The multiobjective optimization literature provides ways for the tradeoffs between interconnected objectives to be characterized, which lays the ground work for making sustainability decisions while considering all three sustainability elements together [47]. Various work has been done that begins to link multiobjective optimization tools to the needs of sustainable design [66], yet the value of characterizing the sustainability space and using it for decision making in sustainable design has not

been explored [76]. This paper introduces a deliberately quantified tradeoff space between social, economic, and environmental sustainability that can be used to evaluate all three simultaneously during the design exploration process.

2.3 Tradeoff Exploration Using a Product's Sustainability Space

In this section, we present a 5-step process for exploring the sustainability space. This begins with characterizing (or finding) the multiobjective sustainability space (Steps 1-4), followed by navigating through it, and finally with making a decision based on what was learned in the navigation (Step 5). The 5 steps are:

1. Identify sustainability issues
2. Link issues to parameters
3. Aggregate parameters
4. Find sustainability space
5. Explore sustainability space

The 5-step process is presented as simply what could be done by an organization wanting to explore the sustainability space. We also follow the same 5-step process in the example as it serves to break up a more complex discussion into 5 manageable pieces.

The process presented herein is used to link parameters that define the design of a product to the performance of that product in each of the three pillars of sustainability. The process is built on the following assumptions:

Assumption 1: Design teams directly control independent parameters. These independent parameters define the design features. They include, for example, basic geometry and materials among other things. During the product development process, design teams choose specific values for independent parameters as a way to define a product that meets market needs.

Assumption 2: Design teams indirectly control dependent parameters. Design teams are generally aware of how independent parameters influence dependent parameters. For example, design teams know that certain combinations of geometry and materials (independent parameters) will result in more or less product mass (dependent parameter, in this case). Some design teams explicitly evaluate dependent parameters, others do not.

Assumption 3: Independent and dependent parameters can, in any combination, influence top-level dependent parameters (commonly called *design objectives*) that are often used in decision making. For example, the mass of a product (dependent parameter) influences the environmental sustainability as does the material selected (independent parameter, e.g., thermoset plastic versus thermoplastic).

Assumption 4: Sustainable product development decisions can be made in the context of three top-level dependent parameters; economic sustainability, environmental sustainability, and social sustainability [77]. As long as the independent parameters are constrained to be within reasonable bounds, the decision should be dominated by these three dependent parameters.

Assumption 5: The following five steps assume that the initial parts of the product development process have already been carried out and a general design concept has been selected. For example, this would mean that if a team were hypothetically modeling a hypodermic needle, the following steps begin after a needle concept has been chosen rather than an open-ended drug delivery mechanism (which could include a capsule or a needle).

We follow the simple and logical 5-step process here to explore the sustainability space. We note that while economic and environmental sustainability are intuitive in nature, social sustainability is not. For this reason, throughout the explanation of the method, brief references to a hypodermic needle will be made, as needed, to clarify certain aspects of the process. A detailed explanation and results of a hypodermic needle example are presented by Mattson et al. [76]. No equations or results are presented for the needle as a more comprehensive example of the well-drilling machine is introduced in Section 2.4.

2.3.1 Step 1: Identify Pertinent Sustainability Issues

The goal of this step is to identify the sustainability issues that pertain to the selected design concept. The output of this step is a list of sustainability issues that the chosen product can influence based on its design. Sustainability is a broad topic and issues pertaining to sustainability for a product may have nothing to do with its design parameters and more to do with distribution or company policies. Eventually impacts that cannot be related to product design parameters will not be considered in this method and must be considered in other ways. However, brainstorming all possible impact issues, regardless of their relationship to the product design, is a good place to start.

To do this, the team can start by simply asking what potential positive/negative impacts can this concept have on the economy (profitability), environment, or society? Tools such as the Design Abacus [42] can be very useful for facilitating brainstorming of this nature, as can other analysis tools such as the Eco Indicator or the MET matrix [29]. Outputs from tools of this nature can be distilled down to a smaller set of unique issues that merit inclusion in the decision-making process.

For example, in the case of a for-profit company, profitability is one of potentially many important economic sustainability issues. Market demand, production cost, and selling price are others. Likewise, the team may identify the product's weight, energy consumption, water usage, resource consumption, or carbon footprint to be an environmental sustainability issues worth considering. Often less intuitive, but equally important, is the identification of the social impacts of the product. When considering the design of a hypodermic needle, for example, it is valuable to recognize that the needle's design will have an influence on how painful the needle is to the patient, what vaccines can be delivered with it, and how likely it is that the needle would be used for illegal drug use. She and MacDonald [78], and Lofthouse [40] offer some assistance in thinking about social issues related to products.

It's important to recognize that a given sustainability issue may reasonably fit in more than one of the triple bottom line areas (meaning the areas of economic, environmental, and/or social sustainability). For example, the selling price of a product is both an economic sustainability issue and a social sustainability issue, as it directly influences profitability and social inclusion,

respectively. In such cases, it is valuable to consider the issue in both categories as it could capture important tradeoff conditions. The reason for this will become more clear in Step 3.

In addition to the three areas listed above, there are some product requirements that may be more appropriately treated as a constraint. For example, phlebotomists expect a certain axial rigidity in the needles they're using to penetrate the skin. The team may reasonably conclude that axial rigidity of a needle is not an economic, environmental, or social sustainability issue. In this case, the team can decide that a certain amount of axial rigidity is needed in order for the trained phlebotomist to do his/her job. As such, it can be categorized as a constraint.

Like all brainstorming activities, this step requires the design team to make sure this phase has considered a diversity of issues, and that the convergent phase has resulted in a filtering of the issues based on the values held by the stakeholders.

2.3.2 Step 2: Link Sustainability Issues to Independent Parameters

For this step, the design features that influence the sustainability issues (from Step 1) are identified and mathematical relationships that link them are chosen or created. To be more precise, each dependent parameter is described as a function of independent parameters. The output of this step is mathematical relationships for each sustainability issue that links it to specific design parameters. The result of this step is one or more mathematical equations (d) that are functions (f) of independent design parameters (x). For the i -th dependent parameter (or i -th sustainability issue)

$$d_i = f(x_1^i, x_2^i, \dots, x_{n_x}^i) \quad \text{where } x_j^i \in \{x_1, x_2, \dots, x_{n_x}\} \quad (2.1)$$

Notice that by Eq. 2.1, not all independent parameters (x) will map to all dependent parameters (d). For this, the notation x_j^i is used to mean the j -th parameter in the set x^i , which is the set of independent design parameters pertaining to the i -th dependent parameter.

There are a variety of ways to carry out this step; the mathematical relationships may be based on the physics of the product, or they may be empirically derived from a set of experiments or other data, or they may be a simple mathematical relationships based on the designer's intuition. In linking dependent and independent parameters, Kishita et. al. use an ecodesign check list, then examine each checklist item and connect it to product requirements and eventually to independent

parameters [79]. As is the case with many design methods, the design team must choose models and relationships that support their philosophy, such as an eco-efficiency philosophy [80] or an eco-effectiveness philosophy [81]. The relationships developed should support one or both of these philosophies.

We emphasize that while higher detail, higher fidelity, mathematical models will result in more accurate portrayals of the tradeoff relationships, even low fidelity models – if made with care – are better than no model at all. To make this clear, consider the skin penetration pain associated with a given needle design. The team could choose to not model pain, given that it is a difficult and uncertain parameter, but not modeling it would either (i) ignore that pain exists, or (ii) rely on the design team’s members to use his or her own mental model of pain. We would argue that most mental models can be sketched as a function. From these sketches simple mathematical models can be extracted using curve-fitting techniques, even those available in ubiquitous software, such as Microsoft Excel. An example of this is provided in Section 2.4. The value of developing a mathematical representation is that it can then be used in a computational setting to explore various parameter value combinations.

2.3.3 Step 3: Aggregate Independent and Dependent Parameters into Single Measures of Economic, Environmental, and Social Sustainability

In this third step of the process, all the models resulting from Step 2 for economic sustainability are combined into a single measure of economic sustainability (S_{eco}). The same is done for environmental sustainability (S_{env}) and for social sustainability (S_{soc}), separately. The output of this step are three equations, one for each sustainability category, that have been aggregated from the equations created in Step 2. For economic sustainability this can be expressed generically as:

$$S_{eco} = f_{eco}(d, x) \quad (2.2)$$

For environmental sustainability:

$$S_{env} = f_{env}(d, x) \quad (2.3)$$

And for social sustainability:

$$S_{soc} = f_{soc}(d, x) \quad (2.4)$$

where d is a set of dependent parameters and $d \in \{d_1, d_2, \dots, d_{n_d}\}$, x is a set of independent parameters and $x \in \{x_1, x_2, \dots, x_{n_x}\}$, and n_d and n_x represent the number of dependent and independent parameters, respectively. Note that these single measures are aggregations of all issues categorized as relating to economic sustainability, environmental sustainability, and social sustainability, respectively. This has been done for visualization and decision-making convenience. For issues that have been categorized into more than one sustainability area, their influence is captured in both areas by including it in both aggregate measures.

The most common aggregation approach for creating the measures represented by Eqs. 2.2–2.4, though not without flaws [54], is the weighted sum approach. Some alternative approaches that are not as popular, though they overcome some of the drawbacks, are the weighted square sum method, weighted product method, compromise programming method, and Analytics Hierarchy Process (AHP) method.

2.3.4 Step 4: Find the Sustainability Space

Once Steps 1-3 are complete, the sustainability space can be identified using traditional multiobjective optimization techniques. The output of this step is a set of Pareto solutions that can be evaluated by the design team. The multiobjective optimization problem formulation in Eq. 2.5 seeks values of x that maximize the sustainability measures, subject to constraints:

$$\begin{aligned} & \underset{x}{\text{maximize}} \quad S_{\text{eco}}(d, x), S_{\text{env}}(d, x), S_{\text{soc}}(d, x) \\ & \text{subject to} \quad d_{\min} \leq d \leq d_{\max} \\ & \quad \quad \quad x_{\min} \leq x \leq x_{\max} \end{aligned} \tag{2.5}$$

where the only three objectives maximized are economic, environmental, and social sustainability. Recall that as a result of Step 1, some issues were categorized as constraints. As per Eq. 2.5, the maximization of the economic, environmental, and social sustainability is subject to those constraints.

There are at least two strategies that could be used to solve this multiobjective optimization problem. One way is to search for a single optimal design based on an aggregate objective function, such as a weighted sum of objectives. When this strategy is chosen, it is important to rec-

ognize that the choice of aggregation and weights can significantly affect the outcome. A different strategy is to identify a set of non-dominated solutions that can be considered optimal candidates for the design team to choose from. Any Pareto frontier generation method can be used to identify this set, including the normal constraint method, the normal boundary intersection method, or multiobjective genetic algorithms. This strategy allows the design team to view the whole design space and choose an optimal design accordingly. Both methods have been shown in Section 4: Step 4.

The results of this step is a three dimensional Pareto surface, which represents the non-dominated tradeoff conditions between the three essential areas of sustainable development. This surface can be incredibly valuable in the decision-making process because it captures the intricacies of the tradeoff relationships and only presents solutions that have already been improved as much as possible without giving up anything in exchange.

2.3.5 Step 5: Explore the Sustainability Space and Choose a Specific Sustainable Design

The Pareto surface resulting from Step 4 can now be explored, which means that the design team can start to understand the nature of the tradeoffs between the three main objectives. Because the space is three dimensional, a number of traditional visualization techniques could be used to better understand the space.

Upon examining the sustainability space, it will become more clear to the product development team which parts of the sustainability space are desirable to the overall objectives for the product, and which areas are not. From the desirable areas the team should choose a few designs to present to the decision makers. The final decision can then be made based on the tradeoff conditions in the sustainability space, the condition of the constraints, the corresponding values for the independent design parameters, and importantly on the basis of any other unmodeled objective that is important to the stakeholders.

In the specific case of seeking a sustainable design, there is one special condition in the design space that is worth noting here. This condition relates to the concept of weak-Pareto optimality. While not generally of interest in traditional settings, solutions considered weakly Pareto optimal have an interesting meaning in the sustainable design space. To understand this, consider Fig. 2.3. This figure shows two dimensions of interest: Economic sustainability and social sustain-

ability. Both are being maximized; the Pareto surface is shown as a heavy dark line. Regions of the Pareto frontier that exhibit very small change in one objective, given very large changes in another are considered weakly Pareto optimal. They are considered as such because while the solutions in the weak-Pareto region are mathematically different in the objective with small changes, they are not different in practice. The traditional view of this concept is that in the weak-Pareto region we always prefer point A. However, this characteristic has an interesting implication in the case where environmental and social sustainability are valued but not nearly as much as economic sustainability. As such, any design in the weak-Pareto optimal region would be desired over Point A because it would have better social sustainability at practically the same economic sustainability value.

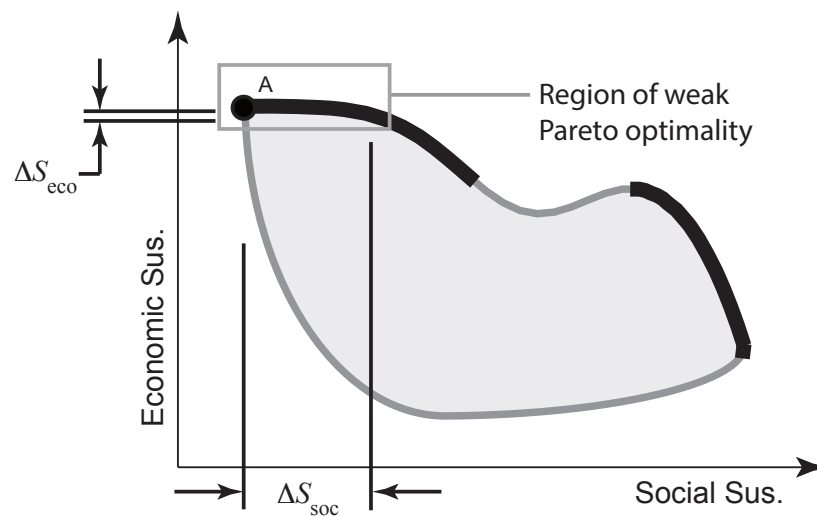

Figure 2.3: The general concept of weak Pareto optimality for two objectives being maximized. Large changes in S_{soc} correspond to small changes in S_{eco} .

While generally deemed useless, it is valuable for the design team to identify areas of weak Pareto optimality as they may lead the team to decisions that have large improvements in one objective while giving up very little in the competing objective.

2.4 Example: Village Drill

We now provide an example of how the sustainability space can influence design. We use the 5-step process presented in the previous section as a way of breaking up the complex discussion into meaningful pieces. We do this for the Village Drill, a machine used to drill bore holes for water

wells in areas of the world that do not have access to advanced drilling processes [45]. The Village Drill is unique because it is human powered and easy to disassemble and transport to a job site. This allows the drill to reach villages in areas that are unable to create bore holes using modern drilling rigs. The drill is currently being used to provide clean drinking water to hundreds of thousands of individuals in parts of Africa, Asia, and Latin America [45].

The Village Drill was designed by Brigham Young University under the direction of WHOlives.org. Five years after its introduction to the market, the impact of this drill was critically evaluated by Mattson et al. [45], giving WHOlives.org the opportunity to more deeply assess the drill's sustainability.

The Village Drill has been chosen as an example in this paper for two reasons: 1) The impact of the drill is documented with data that can be used for creating sustainability relationships, and 2) the relationship between the authors and WHOlives.org allows easy access to product documents normally only accessible to the design team. In this way it creates a realistic situation similar to what a typical design team may experience when implementing the process presented in this paper.

We assume that WHOlives.org wishes to continue producing a drill similar in concept to what is currently being produced (as opposed to producing a drill with a completely new geometry and mechanisms), but the development team has freedom to change the drill dimensions and a few select features. The general concept that will be modified for sustainable product development is shown in Fig. 2.4.

Drill Operation: The current drill design is operated by 3-4 wheel operators, a slurry pump operator, and a winch operator. The drill is disassembled and transported by truck, cart or by hand to a new drill site. The current assembly consists of 6 assembly pieces for the main structure, 17 pieces to build the wheel and spokes, and over 80 lengths of pipe just under 1 meter long for the drill string. The wheel operators drill into the ground by continuously rotating the wheel assembly while a winch operator keeps tension on the drill string to prevent the string from wedging itself into the ground. Strategic use of the winch allows the wheel to turn easily while maintaining a good cut at the drill bit. After a full length of pipe has been drilled into the ground the team stops the wheel rotation and attaches another length of pipe to the drill string. They then re-attach the

square cross-section kelly bar on the other end of the pipe and continue drilling. This process is continued until the drill team has reached the desired depth for the well. The winch is also used to retract the pipe at the end of the drilling process. The slurry pump is used while drilling to push a water/bentonite mixture down the drill string to remove cuttings from the hole and seal the bore hole walls.

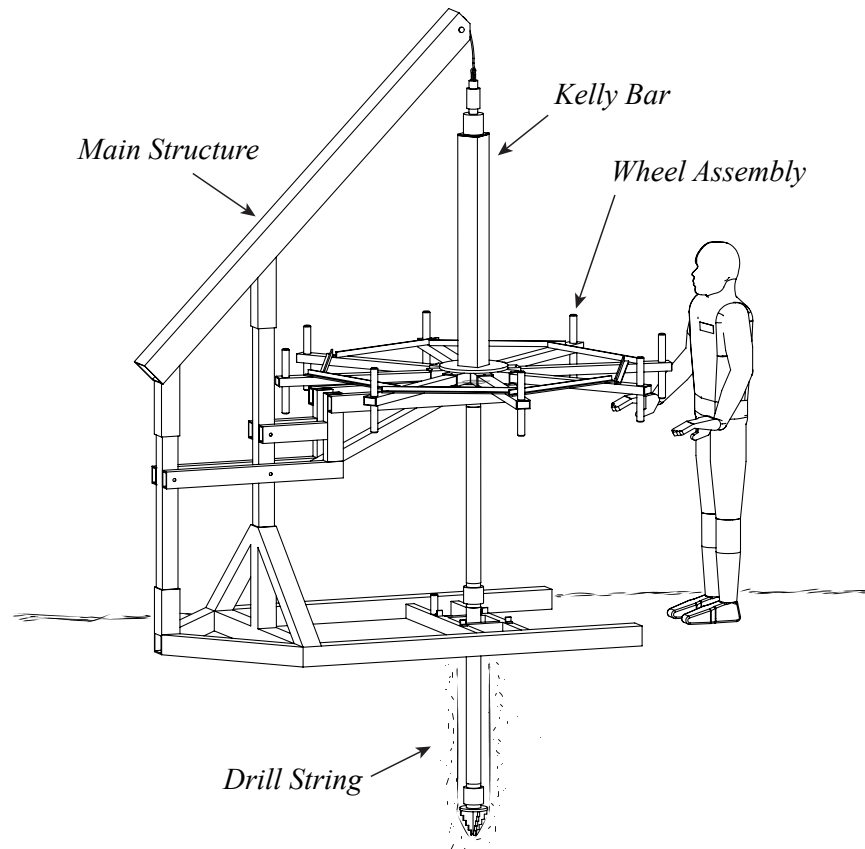

Figure 2.4: The general drill concept, with drill pipe attached.

2.4.1 Example: Step 1 (Identify Sustainability Issues)

The first step is to identify the sustainability issues that are pertinent to the current design. For this example, the following is identified.

1. Economic Sustainability

- (a) cost to produce the drill
 - (b) selling price of the drill
2. Environmental Sustainability
- (a) manufacturing process emissions
 - (b) shipping emissions
 - (c) ongoing emissions from drill operation
3. Social Sustainability
- (a) number of people served water
 - (b) jobs created
 - (c) potential for driller injury
4. Design Constraints
- (a) structurally safe
 - (b) geometrically feasible

Clearly this list is not exhaustive but is sufficient to illustrate the process. More importantly, however, the list represents key measures that are important to WHOlives.org and other stakeholders and users of the product. Several more factors could have been considered in each category. Undoubtedly the more detailed and comprehensive we make the list the more accurately we can characterize the design space. In many cases, the design team will need to decide between developing a high-fidelity expensive model or developing a low-fidelity inexpensive model. Both model types are valuable and for this example we have developed a medium-fidelity model to promote a discussion of ways the model could be increased or decreased in scope to meet an organization's needs.

2.4.2 Example: Step 2 (Link Issues to Parameters)

The purpose of Step 2 is for the team to link the sustainability issues identified in Step 1 to independent design parameters that define the drill. Fig. 2.5 shows the chosen concept and

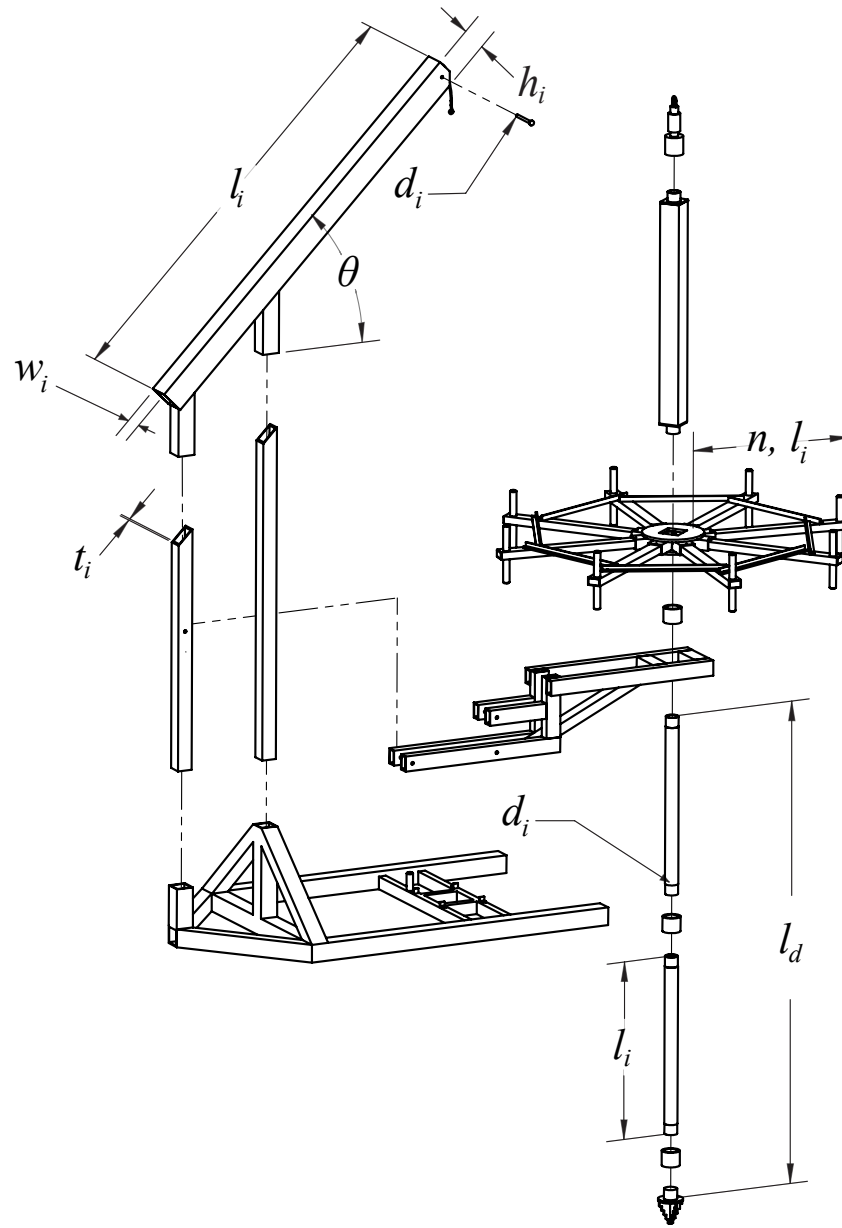

Figure 2.5: Examples of a few of the independent parameters for the Village Drill example.

basic parts of the Village Drill. We have chosen 16 independent variables which include the basic geometry dimensions (l , w , h , t) for most structural members, the angle (θ) of the cantilever beam, the number of spokes (n) and the maximum depth the drill can achieve (l_d).

In the following sections, we show how models can be created to link the identified issues to the independent parameters. These models illustrate that sustainability issues can be considered

– at least in a preliminary way – without large expense or extensive expertise, both of which have deterred many from engaging in sustainable design.

For this example, we know – or can discover with a small amount of research – certain relationships that will exist between the independent parameters and the sustainability issues. Figure 2.6 shows the basic relationships for one of the independent parameters (wheel assembly diameter, d) to three of the sustainability issues listed in Step 2 with actual data represented by black dots. From this figure we make two essential observations: (1) simple mathematical relationships can be created, given just a few specific values for points along these curves, and (2) knowing or visualizing the relationships for realistic problems is not by itself enough to easily conclude what specific values should be given to the independent parameters. Thus, characterizing the many relationships (which go well beyond the relationships shown, to include those for the many other independent parameters and all higher order effects) is more easily carried out in a computational setting than in one’s mind.

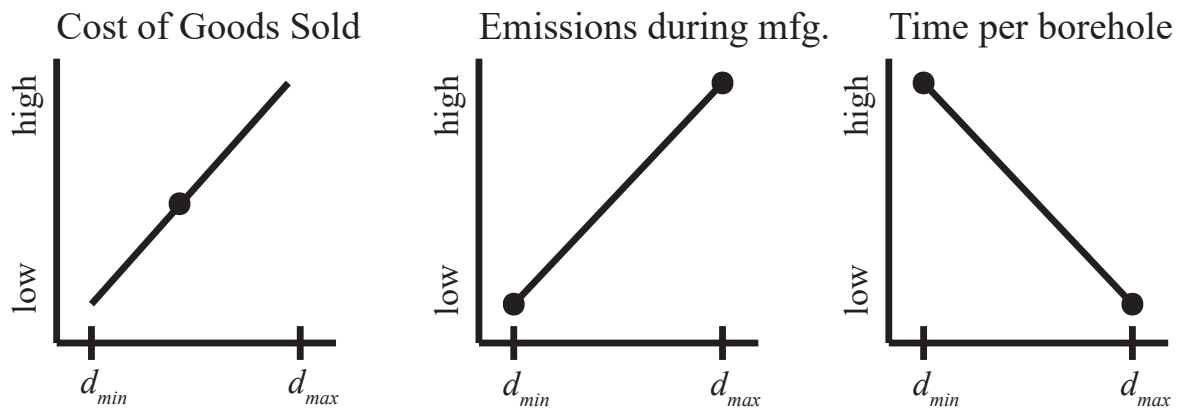

Figure 2.6: Basic relationships between the wheel diameter and a few dependent parameters. The black dots represent actual available data.

Cost to produce the drill

The cost to produce the drill is a function of the amount of material in the final drill design (including scrap), the amount of welding that is needed for assembly, and the cost of each piece of

hardware required for the drill. Specifically, the total cost (C_{tot}) is

$$C_{tot} = C_{mat} + C_{wld} + C_{hdwr} \quad (2.6)$$

where C_{mat} is the material cost, C_{wld} is the cost to weld the individual pieces into the final assembly and C_{hdwr} is the cost of the nuts, bolts, washers, etc. These are calculated as

$$C_{mat} = \sum_{i=1}^n A_i l_i \rho C_i \quad (2.7)$$

where A_i is the cross-sectional area of the i -th member, ρ is the material density, and C_i is the cost per gram of the selected material for the i -th member. C_{wld} is calculated as

$$C_{wld} = D_{wld} C_{wld,rate} R_{wld} \quad (2.8)$$

where D_{wld} is the weld perimeter, C_{wld} is the welding cost per hour, and R_{wld} is the weld rate in units of mm/hr. Because the basic design of the drill is static we assume the number of welding locations will not change, only the amount of welding required at each location.

Selling price of the drill

WHOlives.org currently sells the drill for \$18,000 USD [45]. Their current marketing strategy does not allow them to adjust the selling price based on the cost of goods sold. Because their goal is to bring social benefit to impoverished areas they have decided, for the time being, to hold the selling price at \$18,000 USD. They may increase the selling price of the drill in certain circumstances, but for this analysis we will keep the selling price constant. Therefore the equation for P , the selling price of the drill, is

$$P = 18000 \quad (2.9)$$

Carbon footprint

According to the International Organization of Standardization (ISO) the carbon footprint of products (CFPs) should consider “raw material acquisition, production, distribution, use and

end-of-life” [82]. Following this standard, we have summarized the drill’s environmental impact to include manufacturing, shipping, and ongoing emissions. The drill’s ‘end-of-life’ emissions only needs to consider the shipping emissions to a recycling plant and from there its emissions are considered in the material acquisition for the next product.

The US Environmental Protection Agency publishes best practices and useful data to calculate a product’s carbon footprint [83]. A general equation they recommend using is

$$\varepsilon = E_f \gamma \quad (2.10)$$

where ε is the emissions, γ is the activity data (e.g., fuel consumed, or material input) and E_f is an emission factor that calculates the emissions based on the activity [83]. The EPA also provides emission factors for most common processes and is the source for all emission factors used in this example. These emission factors will generate emissions in grams of CO₂.

Manufacturing emissions: The major carbon contribution for manufacturing is in acquiring and forming the steel. $E_{f, stl}$, as defined by the EPA, uses the total mass of steel needed in the product to calculate the carbon footprint due to acquiring and forming the steel. A second major process in drill manufacturing is the welding required for assembly. An emission factor, $E_{f, wld}$, was used for welding to calculate emissions based on the total amount of electrode consumed. The total emissions for manufacturing the drill is

$$\varepsilon_{mfg} = E_{f, stl} \sum_{i=1}^n m_i + E_{f, wld} \sum_{i=1}^n p_{w,i} \quad (2.11)$$

where m_i is the mass of the i -th member and $p_{w,i}$ is the total welding required on the i -th member.

This measure is a good example of an opportunity for the design team to increase or decrease the fidelity of the model. The mass of steel being manufactured is proportional to the amount of emissions that are released. A design team may choose to simply use the total mass of the Village Drill as a surrogate model with the understanding that as the mass of the product increases so will the emissions. If this strategy is pursued it will save time on model development as the team will no longer need to choose emission factors or even create the equations needed to report carbon emissions. However by making this simplification, the measure would only show a relative impact

on the environment and not the actual carbon emissions. If the parameter-impact relationships are normalized then a relative measure is sufficient for characterizing the sustainability space

Furthermore, a team may wish to report stronger evidence of improvement to their stakeholders. In this case they may take the model a step further to discover the emission factors for the exact processes within a specific factory they wish to use. This may require several field tests at the factory to develop a true accounting of the emissions their product will have. The team may also decide to use the emission factors and manufacturing costs of several factories as independent variables. This will allow the model to choose the most economical and environmentally friendly solution. Such a model would increase the time and cost to develop, but the increased fidelity may be what the organization or investors require to show increased sustainability. Our medium fidelity model grants a close approximation to the actual CO₂ emissions during manufacturing, but does not have the added detail of factory-specific data.

Shipping emissions: Vehicles used for shipping typically have relatively low fuel efficiency and have high carbon emissions. The EPA provides an emission factor for light duty trucks used in shipping. The relationship used for calculating emissions due to shipping is

$$\epsilon_{shp} = D_{shp}E_{f,shp}m_t \quad (2.12)$$

where m_t is the total mass of the drill in metric tons, and D_{shp} is the furthest distance, in kilometers, the drill may be shipped from the factory. WHOlives.org ships the Village Drill from a factory in Kenya when the destination is within 2000 km of that factory. Therefore, we assume a worst case scenario and set the shipping distance (D_{shp}) to 2000 km.

Ongoing emissions: The drill design implements a slurry pump used to push a water/bentonite mixture down the drill string to assist in the drilling process. This pump uses a 3.7 kW (5 hp) engine and its emissions are calculated as

$$\epsilon_{\infty} = E_{f,pmf}I_d n_{bpm} f \quad (2.13)$$

where f is the amount of fuel, in liters, required to drill one bore hole and $E_{f,pm}$ is an emission factor for the pump based on the amount of fuel the pump uses. The variables l_d and n_{bpm} refer to the life of the drill in months and the average number of holes a drill will make in a month. This data is provided by Mattson et al. [45].

Number of people served

Mattson et al. [45] have also shown that the number of people who are served water is linearly proportional to the rate at which a drill can produce a bore hole. The measure they use is the number of boreholes produced per month n_{bpm} . There are many complex factors that determine the actual number of holes produced, many of which are beyond what the drill design can influence. The two drill parameters that influence the hole production rate are the time it takes to drill a hole and the operating costs per hole. The expression can be written as

$$N_{ppl} \propto n_{bpm} \quad (2.14)$$

and

$$n_{bpm} \propto \frac{2}{\hat{t}_{pb} + \hat{C}_{op}} \quad (2.15)$$

where t_{dp} is the average time it takes to drill one hole, and C_{op} is the operating cost to produce one bore hole, both variables have been normalized, as indicated by the $[\hat{\quad}]$ symbol. A proportionality is used here because the number of people who are served water is not equal to the number of boreholes produced each month, nor are the number of holes produced each month equal to the amount of time it takes to drill one bore hole. Instead we do know that if the time it takes to produce one bore hole decreases, then the number of boreholes produced each month will increase, and the number of people impacted will increase at the same rate [45]. Normalization for these two variables, and for normalized variables in future sections, is done after results have been found for each drill design in the population. The data is then normalized between 0 and 1 using the maximum and minimum values.

The parameters of the drill are closely tied to both elements of equation 2.15. The time it takes to drill a borehole is dependent on the number of operators, the rotation rate (RPM) of the wheel and the number of stops required by the team to attach additional drill pipe to the drill string.

The drill time equation, in minutes, is

$$t_{pb} = f_{mud} \left(\frac{l_d}{\overline{RPM} * R_{c,soil}} \right) + f_{rock} \left(\frac{l_d}{\overline{RPM} * R_{c,rock}} \right) + n_{stop} t_{stop} + t_{setup} \quad (2.16)$$

where l_d is the depth of the cut, R_c is the cut rate in millimeters per rotation and is provided by WHOlives.org. n_{stop} and t_{stop} are the number and length of each stop respectively, and t_{setup} is the time taken to assemble the drill at the well site before drilling begins. For reference, additional equations and constants used to calculate the borehole drill time are given.

$$P = \frac{\bar{T} * RPM}{9.55} \Rightarrow RPM = \frac{9.55 * P}{\bar{T}} \quad (2.17)$$

$$\bar{T} = 170 Nm \quad (2.18)$$

$$W = 0.2 n_{op}^\dagger \quad (2.19)$$

$$R_{c,soil} = 2.73 mm/rot \quad (2.20)$$

$$R_{c,rock} = 1.176 mm/rot \quad (2.21)$$

$$t_{stop} = 5 min \quad (2.22)$$

$$t_{setup} = n_{parts}^\ddagger \quad (2.23)$$

The cost for operation (C_{op}) considers fuel cost for the slurry pump and worker wages. The equation can be expressed as

$$C_{op} = 0.0083 t_{pb} C_{fuel} + N_{jobs} W_{labor} \frac{t_{pb}}{60} \quad (2.24)$$

where C_{fuel} is the cost of fuel in dollars per liter and W_{labor} is the labor rate in dollars per hour. The number of jobs that the Village Drill provides is a social measure in and of itself and is discussed in more detail in the next section.

[†]Number of required wheel operators. Operators are able to produce 0.2 horsepower each [84]

[‡]assuming one minute per part for assembly

Jobs created

The number of jobs that the drill creates can be expressed as

$$N_{jobs} = n_{op} + 2 \quad (2.25)$$

The drill needs two workers in addition to the wheel operators for each job. The extra people are required to monitor the slurry pump and operate the winch. This also allows the team to take shifts operating the wheel versus the winch or pump. The number of operators can be expressed as

$$n_{op} = \begin{cases} 1 & \frac{0.9\pi d_w}{1.2} \leq 1 \\ \frac{0.9\pi d_w}{1.2} & \frac{0.9\pi d_w}{1.2} > 1 \end{cases} \quad (2.26)$$

where d_w is the diameter of the wheel. This equation says that 90% of the wheel circumference is available for operators to use and each operator requires at least 1.2 radial meters to operate the drill. The other 10% of the wheel is unavailable space for operation because this is where the base structure attaches to the wheel. This equations is conditional because we will assume that there will always be space for at least 1 operator to turn the wheel.

Risk of injury

Injury is an inherent risk found in all machinery, especially machines that require such close human interaction. That injury negatively effects the social impact of the drill. We have, in conjunction with WHOlives.org, identified 4 failure modes of the drill that may potentially cause injury. They are; (i) the number of stops required during operation, (ii) the potential for the cable to fail, (iii) exposed spoke ends, and (iv) excessive force required to operate. Injury, or risk, “may be defined as the measure of probability and severity of an unwanted event” [85]. We use the Injury Severity Score (ISS) as developed by Baker et al. [86] to model severity on a scale of 1 to 6 (minor to maximal/untreatable). Probabilities have been based on data from WHOlives.org.

Required stops: With the current drill design, the team will drill for about 10 minutes then stop to add another pipe length to the drill string. During this process a few situations arise that could

cause injury. First, the coupler used to attach pipes to each other has sharp edges that could cause cuts or abrasions. Second, the nature of the process means there are heavy sections of pipe being handled. Any time heavy pieces of equipment are being moved there is a potential for pinching, wedging, muscle strain, etc. The model for injury during drill stoppage is expressed as

$$I_{stop} = \rho_1 S_1 n_{stops} \quad (2.27)$$

where n_{stops} is the number of stops required during one drill job and ρ_1 is the probability of injury occurring and S is the severity of injuries that may occur. Under this scenario, most injuries will be minor (a 1 on the ISS) but it is likely that injury severity up to 2 (moderate) may be experience. We used $S_1 = 2$ to ensure the most severe cases would be considered.

Cable Failure: The cable has been included in this model because the event of a cable failure often introduces an unknown and dangerous situation, especially when the cable is under variable tension as it is in this case. When a cable fails catastrophically its behavior is unpredictable and could potentially cause severe injury to nearby operators. Injury due to cable failure is expressed by

$$I_{cable} = \rho_2 S_2 (1 - \hat{SF}_{cable}) \quad (2.28)$$

where

$$SF_{cable} = \frac{S_{ut}}{\sigma_{max}} \quad (2.29)$$

$$S_2 = 3 \quad (2.30)$$

Spoke end cap exposure: The original drill design had a plate welded to the end of the spoke, near the handle that operators would grab to spin the drill wheel, see Fig. 2.7a. Later, this plate was removed for manufacturing simplicity, but it leaves the area vulnerable to injury as a finger may get caught in the end of the spoke, see Fig. 2.7b. The potential for injury in this location is expressed as

$$I_{spoke} = \rho_3 S_3 E_p \quad (2.31)$$

where

$$E_p = \begin{cases} 1, & \text{end plate cover present} \\ 0, & \text{end plate cover absent} \end{cases} \quad (2.32)$$

$$S_3 = 2 \quad (2.33)$$

E_p is simply a binary value to identify if the end plate is present or not. If it is, then the potential for injury in that location is 0. If there is no plate then the potential for an operator to get a finger caught in the spoke is 1 times the probability (ρ_3) of an injury occurring.

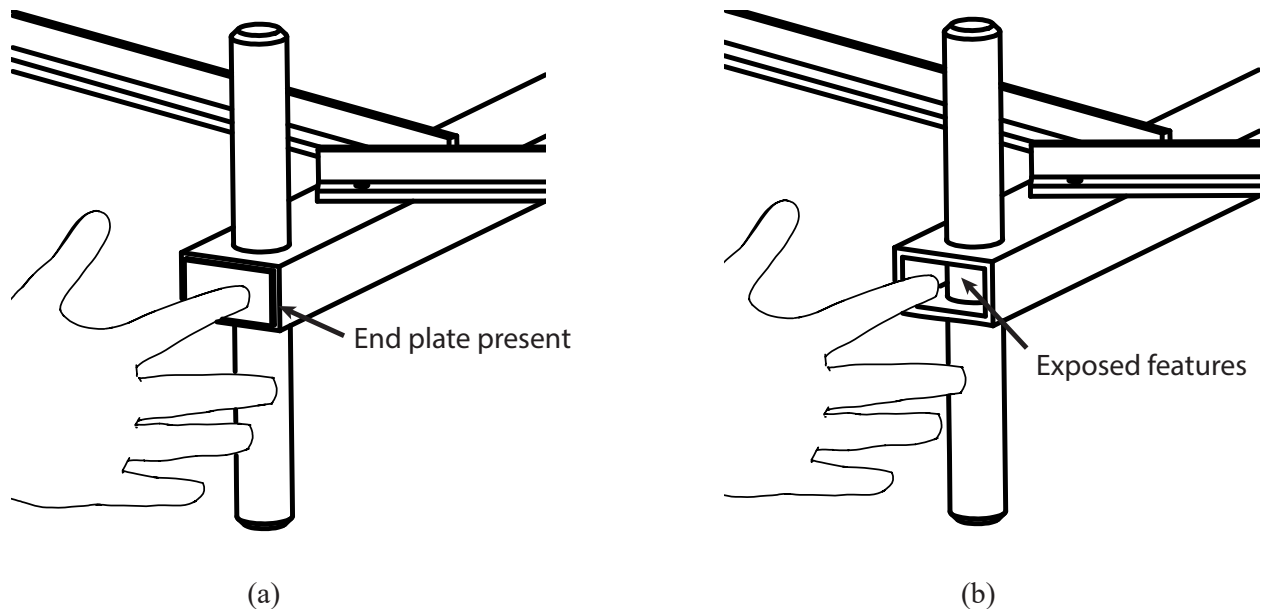

Figure 2.7: Spoke and handle design; (a) shows the design with the end cap on the spoke while (b) shows the exposed features without the end cap. This exposed region poses a potential injury risk for fingers.

Force exertion: The force required to spin the wheel is dependent on the diameter of the wheel. Principles of mechanical design indicate that as the diameter of the wheel increases the force required to produce the same amount of torque decreases. As the wheel diameter shrinks, the operators will have to exert a higher force on the wheel to maintain the required torque on the drill

bit. A higher force will result in higher risk of injury which can be expressed as

$$I_{force} = \rho_4 S_4 F_{op} \quad (2.34)$$

where

$$F_{op} = \frac{2T}{d_{wheel} n_{op}} \quad (2.35)$$

$$S_4 = 1 \quad (2.36)$$

As mentioned earlier, a benefit to developing models in this way is the simplicity in which we can find individual relationships between independent design variables and dependent sustainability impacts. Fig. 2.8 visualizes equations 2.27, 2.28, and 2.34.

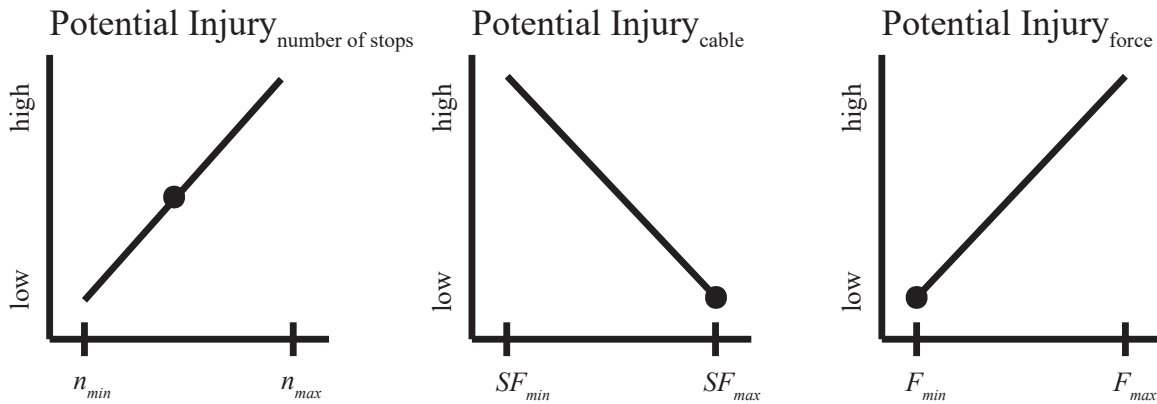

Figure 2.8: Basic relationships between the dependent design parameters and a 3 dependent injury parameters. The black dots represent actual available data.

The potential for injury is the aggregate score of each of the individual injury models. Each equation is normalized and aggregated into the following equation

$$I = \frac{w_1 \hat{I}_{stop} + w_2 \hat{I}_{cable} + w_3 \hat{I}_{spoke} + w_4 \hat{I}_{force}}{4} \quad (2.37)$$

where w_i represents the weight assigned to the specific injury case. In this model each weight is 1.

Comments on social measures: It is apparent that these social measures do not have firmly defined methods of measurement as is the case for economic and environmental impact. For example, economic measures can universally be modeled using dollars, and environmental measures may use grams of carbon emissions as a common unit, but social impacts do not have any common units of measure. Additionally, predicting the exact number of people served requires more factors than simply looking at the number of boreholes a drill can produce, most of which do not involve the drill design at all. Furthermore, the potential for, or the impact of, an injury is another measure that simply can't encompass all possibilities, nor does it have a generally accepted numerical value to quantify it. The purpose of this paper is not to provide the best social measures, but to provide a means for design teams to include social measures in tradeoff analysis, when considering the sustainability of their products.

2.4.3 Example: Step 3 (Aggregate Parameters)

With the mathematical relationships identified in the previous step, we can now prepare to carryout the numerical search for the non-dominated designs by establishing the objective functions of the optimization problem. To do this, we revisit the sustainability issues identified in Step 1 and declare that we wish to maximize revenue as the economic measure, we want to minimize emissions as the environmental measure, and for the social measures we want to maximize the number of people served and jobs created while minimizing injury potential. Let us now consider each one.

Aggregate measure of economic sustainability

We chose to define economic sustainability for this example as revenue. Where revenue is represented as the difference between the selling price of the drill and its production cost. Using Eqs. 2.6 and 2.9 this is represented by

$$S_{eco} = P - C_{tot} \quad (2.38)$$

Aggregate measure of environmental sustainability

Environmental sustainability is represented as the sum of the drill's emissions throughout its life-cycle. Therefore, using Eqs. 2.11, 2.12, and 2.13, the single measure of environmental sustainability is

$$S_{env} = -(\epsilon_{mfg} + \epsilon_{shp} + \epsilon_{\infty}) \quad (2.39)$$

Aggregate measure of social sustainability

We aggregate the three social sustainability issues into one measure using a weighted average. Eqs. 2.15, 2.25 and 2.37 are first normalized and then aggregated as shown.

$$S_{soc} = \frac{w_1 \hat{N}_{ppl} + w_2 \hat{N}_{jobs} + w_3 (1 - \hat{I})}{3} \quad (2.40)$$

where w_i has a value of one in each instance.

There are a variety of ways we could have aggregated these issues into single measures. There are various resources available in the literature to help development teams choose appropriate methods of aggregation [52]. While it is not our intent to review these here, we simply wish to point out that indeed the issues can be aggregated into three measures that represent the triple bottom line.

In the case of the Village Drill, economic and environmental issues have common units of measure ($\$, lbs - CO_2$), therefore combining them was a simple task. The same cannot be said for issues regarding social sustainability. This makes weighting these relationships challenging and subjective in many cases. For example, one stakeholder may feel that it is most important to reduce injury as much as possible, even if that means radically decreasing the amount of water provided. This person would then weight *injury reduction* higher than *water provided*. Varying opinions on the proper weighting may exist even within a single design team. The challenge of weighting social impact issues is still up for much debate and we do not seek to solve it here. Suffice it to say that much work could be done to develop a method for objectively weighting social impacts. Here we simply allow each issue to have an equal weight of one within the aggregation.

2.4.4 Example: Step 4 (Find Sustainability Space)

Given the outputs of Step 3 we can now carry out the numerical search for non-dominated designs within the sustainability space. The problem formulation captures the details:

$$\begin{aligned}
 & \underset{x}{\text{maximize}} \quad \hat{S}_{\text{eco}}, \hat{S}_{\text{env}}, \hat{S}_{\text{soc}} \\
 & \text{subject to} \quad x_{i,\min} \leq x_i \leq x_{i,\max}, \quad i = 1, \dots, n. \\
 & \quad \quad \quad c_{j,\min} \leq c_j \leq c_{j,\max}, \quad j = 1, \dots, m.
 \end{aligned} \tag{2.41}$$

where the objectives are normalized between 0 (worst) and 1 (best), and where x represents the design variables and c represents the constraints. For this model we have 16 design variables and 8 constraints. The constraints are summarized in Table 2.1. The constraints are enforced to ensure the functionality of the drill and manufacturing feasibility is maintained throughout the optimization process.

Table 2.1: These 8 constraint equations are used to filter out infeasible designs in the Monte Carlo simulation.

Constraint	Description
$\sigma_i < S_y * S_f$	Ensures the Von Mises stress in each steel member stays below its yield strength. $S_y = 250$ MPa, S_f (safety factor) = 1.5
$l_{spk} < ((l_1 - x_{dis}) * \cos(\theta) - 200)$	Ensures the wheel assembly will remain at least 200 mm away from the main uprights.
$l_4 > (l_1 * \cos(\theta) + 108)$	Ensures the base extends at least 108 mm beyond the end of the cantilever
$\theta_{twist} < 360^\circ$	Ensures the total torsional twist in the drill string at full length is less than one full rotation.
$(l_{pipe} + 200) < (l_3 * 0.3 + (l_1 - x_{dis}) * \sin(\theta))$	Ensures that the kelly bar can be raised above drill wheel for additional pipe assembly
$l_{pipe} < l_2$	Ensures that a single length of drill pipe can fit under the wheel support weldment for assembly
$u_1 < 50\text{mm}$	Ensures the total deflection of the cantilever is less than 50 mm.
$p_{net} > 0$	Ensures net profit is greater than 0.

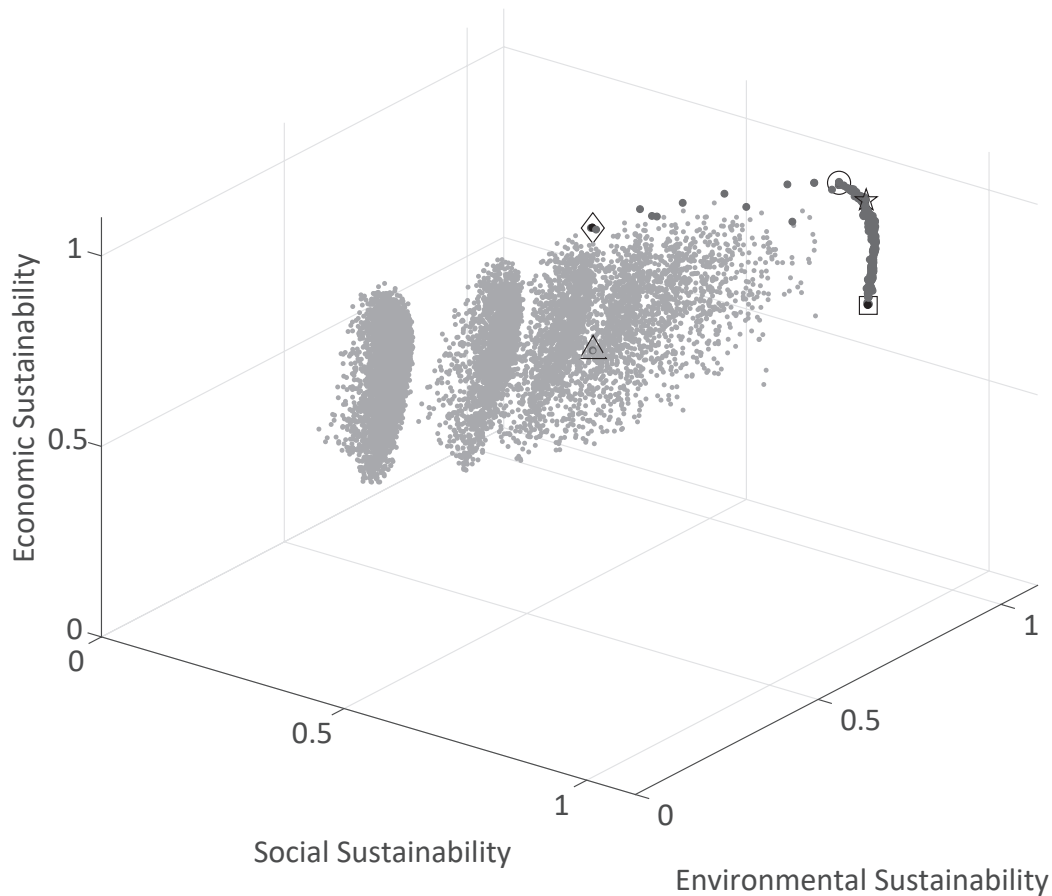

Figure 2.9: Sustainability space, normalized between 1 (best) and 0 (worst), with non-dominated solutions represented by the darker point. The solutions with a square and diamond around it are the drill designs that received the best social and economic score, respectively. The solution with the triangle around it is current Village Drill design shown here for the purpose of comparison, while the solution with a circle around it is used for discussion.

The relationships in Eq. 2.41 are then used to optimize the drill design. Two separate techniques were used to optimize and a monte carlo simulation was used to visualize the design space. The sustainability space is shown in Fig. 2.9. Here, the light gray points represent feasible designs as generated by the monte carlo simulation with two million data points. The darker points represent non-dominated design alternatives (Pareto points) as generated by the optimization. Additionally, separate optimization routines were run for various weights between the three objectives. An optimal solution is found for each pillar of sustainability individually as well as an optimal solution for the condition where all the weights are equal in each category. For simplicity of presentation (scaling, and additional parameter discussion), the data is presented in a normalized

space where 1 is the best, and 0 is the worst. In a publication setting, three-dimensional spaces can be difficult to visualize, so two-dimensional snapshots of the three dimensional space are provided in Fig. 2.10.

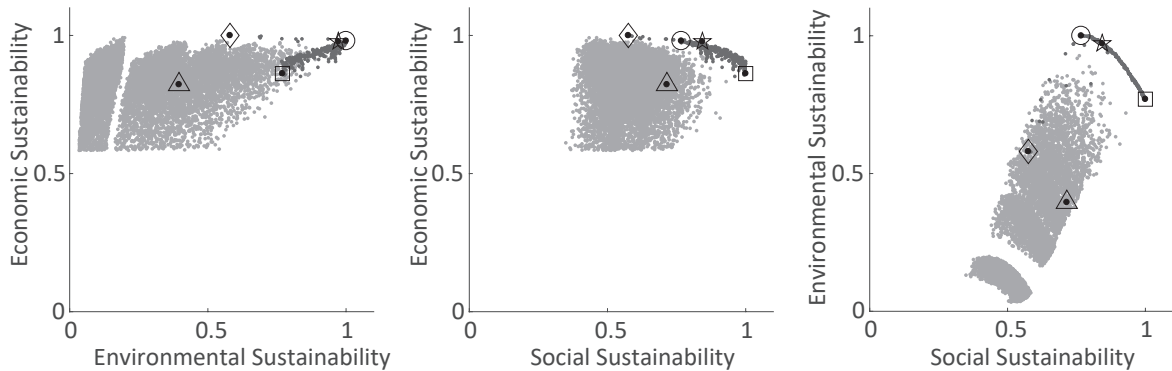

Figure 2.10: Two dimensional snapshots of the sustainability space. The solutions with a square and diamond around it are the drill designs that received the best social and economic score, respectively. The solution with the triangle around it is current Village Drill design shown here for the purpose of comparison, while the solution with a circle around it is used for discussion (see Fig. 2.11 for images of each design). Non-dominated solutions are not highlighted.

2.4.5 Example: Step 5 (Explore Sustainability Space)

Figures 2.9 and 2.10 represent data sets that can be easily interacted with by the development team as a means of exploration. In so doing a significant understanding of the sustainability can be easily understood. Fig. 2.10 shows two dimensional views of the sustainable design space for the Village Drill. The point with a triangle around it represents the current Village Drill design. This figure also shows that, according to our model, the current Village Drill has potential to improve in each of the three categories of sustainability.

One key benefit of this approach is discovering the tradeoffs between each pillar of sustainability. In any design setting, tradeoff information can be a tremendous benefit to decision makers, and in this case it is informative to the designers of the Village Drill. For example, Fig. 2.10 shows three points that are the optimal designs in regard to one specific pillar. These points are

represented by a diamond, representing the best economic point, circle (best environmental) and square (best social). If WHOlives.org desired to focus only on a drill that maximizes economic profits, then the data suggests choosing the design with a diamond around it. However, this results in giving up performance in the other two sustainability pillars, as shown in the right-most image of Fig. 2.10 This design performs poorly in regards to social and environmental sustainability. As WHOlives.org is a nonprofit organization they may be inclined to select the highest performing design for social sustainability, shown with a box surrounding it. Similar to the best economic design, choosing this design also has its tradeoffs.

The design identified as the *Averaged* best (shown in Fig. 2.10 with a star) performs reasonably well in each of the three categories. When compared to the best economic point, this design only gives up a minimal amount in economic sustainability while making significant improvements in social sustainability. While it is not the optimal choice for any of the three pillars of sustainability alone, the tradeoff in each is relatively small. Decision makers may be inclined to choose this design over others because it performs well in each of the three categories despite not being the best option in any of them. The key insight gained by this design space exploration approach is that the current drill can improve in each category simultaneously, with significant improvements being realized in economic and environmental sustainability.

Identifying these tradeoff conditions offers a design team an intuitive way to view the sustainable design space for the drill. In turn, they can then use the information to choose a design that best represents the values of the company and society. Figure 2.11 shows each of the five identified designs and their performance in a few select sustainability issues.

The purpose of step 5 is to determine the best potential designs for the drill. This is done by viewing the sustainability space and evaluating the tradeoffs for each design. A few important observations can be made about the exploration:

1. While it is valuable to visualize the entire sustainability space (as it is easily represented by using the monte carlo approach), the development team will only need to focus on the Pareto solutions as they are by definition the optimal tradeoff surface, where any point on that surface can only improve in one objective by worsening in another. As a side note, the distinct segments in the design space are caused by using discrete values for many of the design variables in the Village Drill.

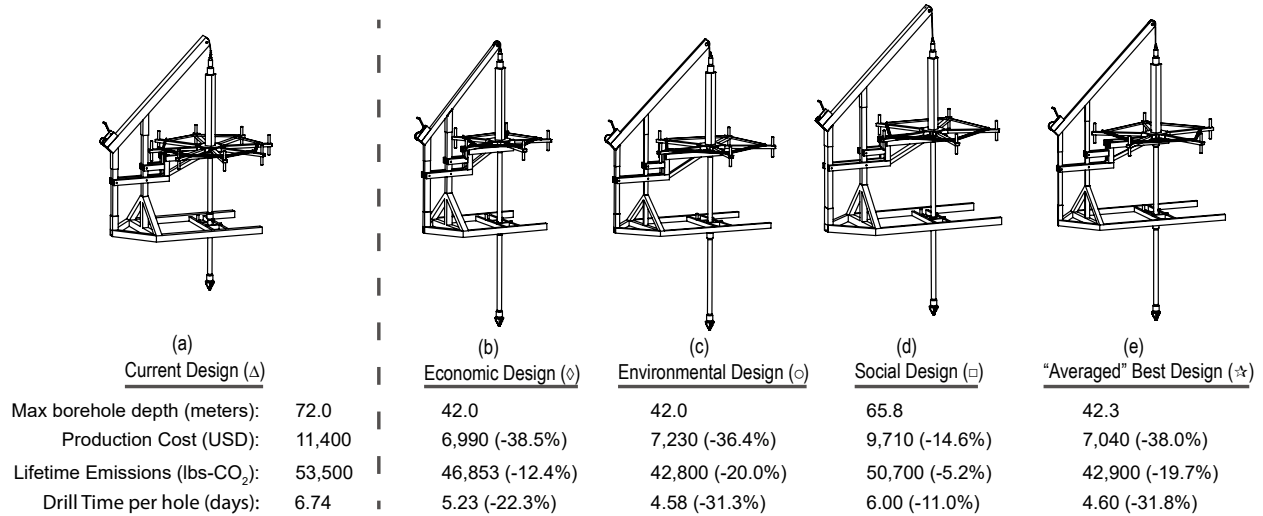

Figure 2.11: Computer generated drill designs resulting from optimization. Additional statistics are also shown for performance comparison.

- When examining two-dimensional snapshots as in Fig. 2.10 it is important to recognize that a highly desirable design alternative in one plot, is not always desirable in the other plots. For example, Fig. 2.10 shows two designs – one marked with a square around it and another with a circle. As seen in the center plot, the square point is the design alternative with the best social sustainability. Because there is a natural tradeoff we would expect this point to not be the best design in terms of economic sustainability nor environmental sustainability. This is shown in the left-most and right-most figures.
- Figure 2.10 shows a design with a triangle around it. This solution is the current Village Drill design. The sustainability space shows that there are several designs that are more sustainable than the design that WHOlives.org is currently manufacturing and selling. This kind of understanding, gained by characterizing the sustainability space and exploring it, can be a valuable part of decision making in sustainable design. This model also implements standard sizes for tubing and hardware, which is important for an optimization model like this because a design team will not be required to round the solution's beam sizes up or down to the nearest standard size, which if done, will immediately affect the optimal solution.
- For this particular problem formulation, there are a few areas of weak-Pareto optimality. These are most easily observed in the center plot of Fig. 2.10. Here we see nearly the same

condition described in Fig. 2.3, which, if identified, can significantly affect the decision-making. Similarly, the solution with a circle around will likely be preferred over the one with a diamond around it even though the diamond design is slightly more economically sustainable.

5. The decision makers can also consider the values of the independent parameters that result in certain designs; this is easily extracted from the computational tool used to characterize the space. For example, the design with the circle around it is a drill design with completely new dimensions from the original drill and increases its performance in each of the three pillars of sustainability.

2.4.6 Example: Discussion

The example of the Village Drill shows that (i) a sustainability space exists for the drill, (ii) it can be characterized with mathematical models, and some experience in numerical optimization. An important message of the example is that the sustainability space is valuable in decision-making. The complexities regarding the sustainability tradeoffs are too great to be understood without computational assistance. Decomposing the sustainability of a product into smaller more manageable issues is an essential part of the presented method. It allows the development team to consider issues of sustainability that can be modeled simply; then it allows the computer to examine all of those simple models simultaneously – leading to insights that may not have been understood by intuition alone.

The results found for the Village Drill specifically are interesting and valuable. All four of the optimal designs recommend reducing the depth capacity of the drill, which results in a smaller segment of villages that can be served by the drill. This seems counter intuitive at first glance, but the optimizer has discovered that it may be more beneficial to drill two holes in two different villages at 42 meters in the roughly two-thirds of the time it takes to drill just one hole in a single village at 72 meters. More obviously, the optimizer has been able to reduce emissions, costs, and drill time in every case. These are results that WHOlives.org can use immediately to adjust the design of their drill to maximize their positive impact in each sustainable category.

2.5 Concluding Remarks

In this paper, we have presented a 5-step process for finding and using the sustainability space to support sustainable design decisions. Having worked closely with the ideas presented herein, we can make the following observations:

1. The identification and use of the sustainability space can bring new insights to decision making in sustainable design that may not be intuitively discovered otherwise. Its value is significant because it characterizes the tradeoffs between economic, environmental, and social impact – which are the three areas of sustainability our products will influence whether we explicitly evaluate it or not.
2. The nature of the sustainability space is too complex to characterize and understand by intuition alone. To an extent, this has stalled many sustainable design efforts over the past two decades, which has caused many to believe in the concept of sustainability but abandon fully pursuing it in practice.
3. While too complex to manage by intuition alone, sustainability can be decomposed into smaller more manageable sustainability issues that can be understood intuitively. This understanding can lead to simple mathematical models (for each sustainability issue) that can be invoked simultaneously in a computational setting to characterize the complex sustainability space.
4. Although the basis for the ideas presented in this paper center on the multiobjective optimization principle of Pareto optimality (or the principle of non-domination), no complex multiobjective optimization algorithm is *necessary* to generate the results presented in this paper. In its basic form, very similar results can be achieved using simple monte carlo simulations and Pareto filtering. This is significant because it means that little-to-no experience in multiobjective optimization is needed to identify and use the sustainability space. On the other hand, using multiobjective optimization, the design team can guarantee that it has completely and rigorously identified the boundaries of the sustainability space.

This method has limitations and perhaps the greatest of which is that it requires a design concept that can be parameterized (recall that the drill design was defined by the geometrical

dimensions of its members: l , w , h , etc). This limits the use of the specific method presented here to *product improvements* and *product redesign* as defined by the Brezet model [29].

A related limitation is that the correctness of the identified sustainability space is based on the correctness of the models used to find it. We must recognize however, that (i) this is true for any model-based design method, (ii) all models exist on a fidelity spectrum, and (iii) a basic part of the product development process includes evolving the models to an appropriate level of fidelity – often over the course of the product development. While the models presented for the Village Drill example aren't of the highest possible fidelity, even a model of low-fidelity – if made with care – is higher fidelity than no model at all.

Another limitation regarding the mathematics is that we suggest aggregating all social issues (for example) into one measure of social sustainability, and so on. Ultimately we believe that making decisions based on the three-dimensional space defined by single measures of economic, environmental, and social sustainability, justifies this limitation. Nevertheless, any aggregation has the potential to reduce decision-making transparency because it generally requires decision makers to assign preference to the aggregation's constituent parts. Future work should address the aggregation of impact metrics for each category in the triple bottom line to improve the value of this model.

Many organizations currently do not approach decision making for sustainable design in a manner that is compatible with the method presented in this paper. For example, some organizations consider each pillar of sustainability individually and in a hierarchical manner. Generally, applying the method described in this paper to a hierarchical situation eliminates the opportunity to explore the sustainability space as thoroughly. This is simply due to the design space reduction that occurs for each level in the hierarchy, which is caused by the decisions made one level up in the hierarchy. The method presented in this paper is offered as an alternative process that would likely require a cross-functional assessment and consideration of sustainability, resulting in models that accurately reflect multiple impact categories. Notwithstanding the cost of cross-functional collaboration, the presented method provides a powerful opportunity to characterize tradeoffs amongst the three pillars of sustainability, and simultaneously optimize each.

In a real sense, the proposed method requires an appreciation for the multidisciplinary aspects of design. It requires engineers, for example, to consider non-engineering areas more deeply

such as those related to the social impact of the product. It requires those who are disinclined toward using mathematical models to value how the models can be used to support design efforts. And it requires those who use the mathematics to translate the outputs into a language and format that decision makers and design teams will engage with. It requires business leaders to distill an organization's sustainable design goals down to a manageable set that can be reasonably achieved given the organization's resources. In each of these cases, the individuals involved must be open to expert guidance, as needed.

CHAPTER 3. THE SOCIAL IMPACTS OF PRODUCTS: A REVIEW

3.1 Introduction

Regardless of whether explicitly considered, every product has economic, environmental, and social impacts [28]. Economic impacts are typically tied to profitability, wages, and employment and have long been considered with respect to product development. More recently, environmental impacts have garnered much interest, resulting in valuable tools that allow engineers to understand better the environmental impact of design decisions (e.g. [9]). Though exceptions exist, social impacts have not yet been the focus of significant research efforts or included in the calculus utilized by engineers to evaluate product design features. Yet, the concept of social impacts — the influence of a product ‘on the day-to-day quality of life of persons’ [14] — has a long-standing tradition in the mechanical and manufacturing engineering professions, whose codes of ethics emphasize holding ‘paramount the safety, health and welfare of the public’ [15] and considering ‘the consequences of [our engineering] work and societal issues pertinent to it.’ [16] Despite the genuine and near-universal acceptance of these sentiments, most practitioners do not commonly characterize the social impact of products beyond the basic principles of mechanical and structural safety. Therefore, understanding the social impacts of design frequently remains out of sight and reach of those who create and manufacture products.

Although literature on the social impacts of products has traditionally been scant, a growing number of resources have been published. Guidelines have been established, such as the United Nations Environment Program (UNEP) Guidelines for Social Life Cycle Assessment of Products, to promote the assessment of the social impact and sustainability of products. A variety of blog posts and other websites offer broad guidance and illustrative case studies. The academic literature devoted to social impacts of products lags behind the attention given to the topic by practitioners in the nonprofit sector. Exceptions include Vanclay [17], Epstein and Yuthas [18], Fontes et al. [19] who note that the relevance of particular social impacts often depend on the local context or

community. Nevertheless, they discuss ways to identify relevant social impacts in these settings; identify broad topics to assess such as environment, community, health, and economy; and provide examples related to these topics.

While these efforts often result in lists of social impacts that scholars and practitioners would do well to consider and represent a useful and growing body of literature, their grounding in empirical research is often limited. Many of these sources that offer lists of social impacts have been generated from the authors' experience or influenced by the authors' 'prejudices and biases' [17]. In this paper, we take a modest step toward addressing this issue by integrating a wide range of studies in the social science and engineering literatures with the intent to better inform our conception of products' social impacts. Accordingly, based on our reading of the literature we too have identified a range of social phenomena that are impacted by products and technology and that fall under the broad themes of population change, family, gender, education, stratification, employment, health and well-being, human rights, networks and communication, conflict and crime, and cultural identity/heritage. In addition to integrating a wide range of literature that comes from social science and engineering literatures on the social impacts of products, we suggest that additional efforts to articulate social impacts should build a cumulative body of research based on previous studies. These efforts should focus on systematically building findings and identifying scope conditions rather than relying on personal experience or bias. Before discussing these social phenomena that are affected by product use based on our literature survey, however, in the next section of the paper we provide an overview of the existing frameworks that call attention to the various dimensions of social life that are impacted by products.

3.2 Existing Frameworks

A growing number of resources have been provided that outline social impacts to consider when designing and implementing a new program or product. Social impact assessment (SIA) is a well-established framework for examining the expected consequences of a planned intervention such as a new policy, program, or technological development on the well-being of a community [87, 88]. Many development projects pursued by non-profit and government organizations today include an SIA component to better understand their consequences [87]. SIA, as outlined by Burdge [14] highlights many dimensions of community life that may be affected. These include

population impacts (e.g. influx of temporary workers or seasonal residents, relocated individuals, and the demographic composition of the population), community and institutional arrangements (e.g. interest group activities, changes in the size or structure of government, and changes in wages or employment), communities in transition (e.g. presence of outside agencies, level of inter-organizational cooperation, introduction of new social classes), individual and family level impacts (e.g. disruption of patterns of daily living and social networks, change in family structure, perceptions of public safety), and community infrastructure needs (e.g. change in community infrastructure, land acquisition and disposal, and effects on cultural or historical resources). Vanclay [17] also provides perhaps the most extensive summary list of social impacts identified to date. These include health and well-being (e.g. social capital, health and fertility, and mental health); quality of living environment (e.g. exposure to safety issues, disruption of daily activities, and recreational opportunities); economic and material well-being (e.g. standard of living property values, and occupational prestige); cultural impacts (e.g. loss of language or cultural heritage); family and community (e.g. changes in family structure or sexual relationships); institutional, legal, political, and equity impacts (e.g. viability of government, violation of legal rights, and access to legal procedures); and gender relations (e.g. women's reproductive rights, women's autonomy, and division of labor)

Epstein and Yuthas [18] build on the insights of Life Cycle Assessment for which social impacts are related to the rights and safety of workers who manufacture a product [89,90] as well as the relevant social impacts of products for their users. The broad impacts that Epstein and Yuthas identify include the environment, community, health, and economy. Epstein and Yuthas also provide sample measures of each impact that are associated with a range of possible outcomes that may be experienced within a particular community (see Figure 21, p. 162). In addition to their measures related to the natural environment, their sample measures of health include, among other things, life expectancy, infant mortality, number of people suffering illness or death, and number of visits to clinics per year. The sample measures of community and economy consist of the same measures and involve perceptions of safety, crime rate, number of community meetings attended, and number of people with access to transportation and latrines.

A recent handbook by Fontes et al. [19] provides a useful and detailed account about how to conduct social impact assessment. The handbook identifies the relevant stakeholders that must

be considered when assessing social impacts as consumers, workers who manufacture the products and participate in the supply chain, and local communities. Fontes et al. [19] also identify social topics to be assessed for each stakeholder and measures related to each topic. Social topics related to workers include a variety of items, but examples include health and safety, discrimination, and work-life balance. For consumers, topics are limited to health and safety, and well-being. For the last stakeholders, communities, examples consist of health and safety, access to tangible resources, and community engagement.

The Technology Assessment literature provides another framework that addresses the economic, environmental, and social sustainability of technology. This interdisciplinary field seeks to understand and minimize potential damage that can arise from uncritical application of technologies, incorporating various methodologies in pursuit of that goal. Such popular methodologies that consider social impact include Constructive Technology Assessment (CTA), which frames technology within a larger societal context, often shaping technology design in order to improve social outcomes [91]. CTA achieves this through focusing on incorporating more stakeholders into the design process. Another noteworthy Technology Assessment methodology is the Social Shaping of Technology [92], which examines the social conditions and context under which technology and innovation come about. From these and various methodologies, a significant contribution of the field of Technology Assessment is the increased awareness in promoting positive social, economic, and environmental impacts while minimizing future damages in designing and distributing technology.

However, the scope of social impact consideration historically has remained limited within this field [93]. An emerging framework, Technology Assessment in a Social Context, addresses these limitations by utilizing the work of Vanclay [17] in SIA to incorporate a greater understanding of social impacts and processes [93].

These frameworks are exceedingly valuable for those interested in understanding a range of social phenomena affected by products and technology; however, they provide little-to-no empirical support as a basis for justifying the categories they identify as social impacts. These frameworks often provide intuitive concepts based on authors' perceptions or described in 'ethnocentric terms' [17], but lack a systematic investigation that generates a cumulative trajectory of work based on previous empirical research. Accordingly, these frameworks that are provided list multiple cat-

egories of social impacts and, consequently, a ‘high degree of inconsistency between such lists’ exists [17].

To be clear, we are not challenging the lists of social impacts generated by previous researchers. But, there is an empirically rich set of studies in a variety of social science and engineering disciplines that are relevant to those interested in the topic of social impacts that remain insufficiently utilized when generating these lists. Myriad studies in social science and engineering disciplines have documented instances of individuals’ everyday lives that have been affected by the adoption or diffusion of new technologies, but no efforts of which we are aware have been made to integrate these literatures. Our review paper represents an effort to integrate these studies into coherent categories and, as a by-product, produce an additional list of social impacts that incidentally is informed by empirical studies conducted in the social science and engineering literatures. Table 3.1 lists the results of our literature search and the columns in the table correspond with each section of the paper outlined below.

In Table 3.1 and our subsequent descriptions of products that affect the day-to-day lives of individuals, we follow Vanclay [17] who distinguishes between social impacts and processes. For Vanclay a social impact influences ‘an actual experience of an individual or community’ (p. 188). This expression of a social impact is similar to Burdge’s [14] cited above. Vanclay portrays a process as a characteristic of the host community. A process is really a social change or intervening or mediating factor that influences ‘whether the community is likely to experience impacts’ (p. 188). Vanclay continues, for example, ‘Local government and other formal organisations, as well as informal organisations such as community groups may experience impacts, but the actual presence of these organisations is not the impact’ (p. 188). We distinguish between process and impact, but we discuss both in our paper because they are closely related; both are often highly salient for social impact assessment. In fact, Vanclay explains, both should be considered together (within the SIA framework) to ensure that the necessary social change processes generate acceptable impacts.

Table 3.1: Social impacts of products as found in the literature

Population Change	Family	Gender	Education
In/out migration; transiency of the population	Alteration in family structure	Gender roles	Education and skills
Relocation of families	Family roles	Gender violence	Community empowerment and capacity building
Presence of seasonal/leisure population	Family's role in society	Gender stressors	Media and other access to information
Introduction of new work population	Family violence	Gender inequality	Product Specific Training
Age structure of the community	Family Stressors		
	Changing family ties		
Paid Work	Stratification	Health & Well-being	Human Rights
Increase/decrease job opportunities	Inequality between community and outside communities	Secure living conditions	Homeless rights
Industrial diversification/change of economic focus	Inequality within community	Safe living conditions	Disabled rights
Local business environment	Social status indicators	Safety and security (real and perceived)	Indigenous rights
Change in employment rates	Social mixing	Activity/exercise	Gender rights
Change in individual's employment status	Introduction of new classes or sub-communities (ex: gangs)	Personal Mental Health	Other minority rights
	Personal prestige	Personal Physical Health	Democracy or decision making participation
	Individual's goals and future opportunities	Morality	
		Personal life/health improvement from product	
		Individual's lingering feelings from usage (frustration, positivity, etc.)	
		Individual's perceived future opportunities/goals	
		Diet	
Networks & Communication	Conflict & Crime	Cultural Heritage & Identity	
Social capital	Potential conflicts	Weakening and strengthening of values	
Networks (relations between actors)	Homicide and violent crimes	Cultural/ethnic/religious ideas and beliefs	
Weakening or strengthening of relationships	Non-violent crimes	Cultural intolerance	
How communication is carried out	Corruption	Cultural/religious rites and practices	
Reliance on participation in the decision making process	Deviance from informal regulations/norms	Cultural/religious artifacts and places	
Relationships between community actors	Potential of assault or attack	Religious demographics	
Impaired or improved personal relationships	Increased or decreased substance abuse	Individual identity reliant on cultural identity	
	Individual noncompliance with rules	Understanding of the universe and the role one plays in it	

3.3 Population Change

Population change includes in- and out-migration, transiency of the population [94, 95]; [96–99], relocation of families [100], presence of a seasonal leisure population, influx of temporary or permanent workers, and changes to the age structure of the community [14, 18]. Advances in transportation technology, in particular, increase access to new places and may affect these population dynamics. The first transcontinental railroad in the United States, finished in 1869, provides an illustration. Labor opportunity initially drew in primarily men from both within and outside of the United States (such as Chinese immigrants) to help with its construction [101, 102]. Populations of the surrounding communities were in flux as the railroad building took place [103, 104]. Once built, there was a greater flow of migrants to the Western United States, which greatly aided in the expansion of western cities [101, 105, 106]. Other studies have shown that improved roads within a community reduce permanent out-migration [107] and rural cities are likely to grow with the introduction of new roads if they are proximate to urban centers [108].

When discussing some of the social changes that stem from new mining operations in rural parts of Australia, Petrova and Marinova [109] report population change as one of the first social processes to appear. Rural Australian mining communities often lack the necessary labor force required to support the mines, which leads to large numbers of workers migrating to these communities. Typically in such circumstances, the workers fly in from other areas, work for a designated amount of time, and then fly back to their homes. This practice leads to increased numbers of outsiders, especially young males, migrating to mining communities [94, 96, 98, 99]. Increases in mining activity that is accompanied by in-migration also introduces new diseases and decreased education quality [94, 95, 98, 99]. As a result, young families have been observed leaving these communities in search of better living conditions [96]. Overall, an increase in mining operations can lead to an atypical demographic structure characterized by a surge in younger, male, transient residents who may come to outnumber permanent residents [97].

3.4 Family

Perceptions of the family's role in society vary by culture; nevertheless, new product adoption can affect the roles the family plays in society, the roles individuals play within the family,

and the stressors that result in strained family relationships. Certain work-related technologies can change the levels of stress or strain experienced within the family. The long absences of family members, predominantly men, engaged in work on offshore oil and gas installations can put strain on both the worker as well as those left behind. While spouses and partners are affected by such a schedule, young children may be particularly susceptible to the strain these situations cause [110,111].

One way products that are used in the home can change family members' roles are by changing the way work is distributed or perceived. Products can affect the roles family members are expected to fill or lead to new obligations members are expected to meet within the home. For example, with the introduction of so many labor-saving household products in the early 20th century such as washing machines, electric irons, gas-powered ovens, and refrigerators, the need for maids or nurses in middle class homes disappeared. As a result, parents in these homes were expected to fill the roles previously taken by nursemaids, including emotional closeness with children not previously observed [112]. Others have pointed out that technological advances can reinforce existing family roles, maintain inequality between family members, and thus have negative impacts on family relations. Thrall [113] suggests that 'when families have an item of equipment which is used for a particular task, they are likely to be more traditional in their division of labor for that task than are families that do not have the equipment.' His study of 99 families living in a Boston suburb shows that husbands are less likely to help with the dishes in families who own a dishwasher. Another study of women's time-use diaries examined for various years beginning in 1925 and ending in 2011 indicates that time-saving home equipment seems to have led to a decline in time women spend doing housework over this period. But these gains were offset by increases in time spent in paid work, childcare, and shopping [114].

Communication technologies have been shown to influence social interaction positively and negatively within the family. Weisskirch's [115] study demonstrates that parents report greater social support from phone calls initiated by children and vice versa, but children report greater conflict when parents call to monitor behavior. Group video chat apps were also found to improve family relationships despite long distances, bringing extended family members such as grandparents into closer relationships with their grandchildren [116]. In a study conducted in Jamaica, parents who lived abroad were more closely involved with their children's lives despite the great distances,

and children reported waiting with anticipation for their parent's weekly phone call [117]. The increased interaction brought about by phones and video chat products may lessen the strain felt by families where one or more members may be away for extended periods of time. In a study of cell phones and work-related communication in Rwanda, researchers found that roughly two thirds of phone usage consisted of interactions with family and friends [118]. Even when cell phones are purchased for work-related reasons, they are often used for strengthening family relationships [119, 120].

3.5 Gender

Technological advances can impact gender norms and expectations. Or, gender norms can be reproduced through these technologies. Online social media can be used to reproduce or express gender identity [121]. Moreover, as mentioned, labor-saving household devices may be used to reinforce gender roles, though time spent doing different household tasks has increased [112–114]. Gender roles outside of the home can change as well. The adoption of email in the workplace has allowed women to overcome the norms of face-to-face conversation that typically put them at a disadvantage. In this way, email and other online forums may increasingly allow women's voices to be heard [122, 123].

The availability of contraception and assisted reproductive technologies (ART) such as in vitro fertilization (IVF), donor eggs, and egg-freezing have had a tremendous impact on women in particular. In addition to women's increasing participation in the labor force and higher education that have also played important roles [124], contraception and ARTs have given women more control over the timing of childbirth, and ARTs have expanded opportunities to conceive and bear children at older ages [125]. In the United States, the average age of first-time mothers has increased from 21.4 years in 1970 to 25.0 years in 2006 [126] while the first birth rates for women ages 35 through 39 has increased from 1.7 percent 1973 to 11.0 percent in 2012 [127]. Of course, control over the timing of child birth provide women with more flexibility regarding the pursuit of educational and employment opportunities, but it also can affect their identity. Interviews conducted with 79 couples who had a child born from a donor egg and who were typically older than many other parents, indicate that women often adopted the identity of an 'older mother.' These women often experienced a negative stigma associated with being an older mother, which

commonly occurred through social interactions with others in public places like playgrounds and schools. These negative stigmas center on others' assumptions or expectations about the mother's infertility, her dependency on a donor egg to get pregnant, being the child's grandmother rather than the mother, or being less physically capable than younger parents [125].

3.6 Education

Education can come from a variety of sources, such as formal in-school learning or informal skill acquisition. Products and technology can influence educational opportunities by enhancing the delivery of information, providing increased access to education (e.g. online courses), or informally through using the product itself (i.e. learning to use and operate a product). An iPad provides an illustration of a product that can be used in an educational setting. Shah [128] observed that iPad applications helped special education students to interact and communicate better. Applications on the iPad were better suited to children with poor motor skills than a desktop computer and was easier to use for those with vision problems. Another example of a product used for improving education is the use of virtual reality for medical students in teaching surgical procedures. Haluck and Krummel [129] discuss the tremendous potential of surgical simulations to help medical students prepare for surgery by learning and refining their surgical skills in virtual settings without the risk of harming live patients.

Using other products also promotes informal educational opportunities as users are required to receive training to properly operate the product. Such is the case for the Village Drill, a human powered drill intended to bore holes for wells in developing countries. The setup and operation of the drill, as well as the installation of the accompanying pump, all require knowledge of the equipment to be successful. Customers who purchase the drill are also trained in its use [45]. As well as learning how to operate the drill itself, customers are trained in how to locate water sources and trouble shoot problems that may arise such as the drill getting stuck. Lastly, another product that generates informal learning is Family Story Play, a product that includes reading materials and video feeds for children [130]. Family Story Play encourages families living apart to engage in activities specifically designed to help young children learn and develop reading skills.

3.7 Paid Work

Products and technologies have been observed in a number of instances to promote better employment opportunities [120,131–134]. Many new jobs may be become available to those living in a community as a result of the adoption or widespread use of a product. Or, employment may be negatively impacted by the production and use of other products. van der Voort and Vanclay [135] report that earthquakes in the Netherlands resulting from natural gas extraction has caused property damage, and consequently, lost revenues for businesses. Individuals who are affected may need to miss time at work as they repair property damage. Okeagu et al. [136] observe that the natural gas and petroleum industries in Nigeria benefited from the global oil crisis in the 1970s. However, pollution caused by natural gas and petroleum production also displaced many farmers and rural residents, forcing them to migrate to cities to find work.

The nature of employment has changed for many employees with the widespread adoption of information and communication technologies (ICTs), which have generated both positive and negative impacts. Chesley et al. [137] suggest that the use of information technologies has blurred the boundaries between work and home by making it difficult for employees to escape from workplace tasks and responsibilities when they are at home. In another study, Chesley and Johnson [138] demonstrate that ICT use improves an employee’s ability to do her job. However, ICT use also increases the amount of stress experienced on the job — stress that is likely due to blurred boundaries between work and home or negative spillover from work to family life.

Products designed to complement or replace human labor, such as factory automation, change the nature of employment at those factories, particularly for unskilled to specialized labor [139–141]. Manufacturing, printing, and publishing industries in particular are affected by microprocessors and other technological advancements [140]. Or, products can improve an individual’s employment prospects. Such is the case with respect to lightweight prosthetic limbs, which allowed military veterans to complete a full day’s work and gain better employment [142].

3.8 Stratification

Social stratification, or the system by which the society ranks groups of people in a hierarchy according to their characteristics (e.g. economic, racial, religious, etc.) [143] is also affected

by the adoption of new products and technology. Advances in technology can impact employment prospects for people who have certain job-related skills [2, 109, 112, 131, 133, 134, 136, 144, 145], but they can also affect inequality in a community [133, 146, 147] or the unequal distribution of revenue or other sources of income [136].

Consuming particular products may also contribute to stratification by signaling a certain social standing or status to others [148]. A product that is manufactured from expensive materials may only be available to those who occupy the highest socio-economic status. Furniture, clothing, and automobiles can be examples of such products [149], and the form or design can greatly influence this perception. Though he was writing some time ago, Fussell [150] argues that upper-class Americans prefer British designs, which are deemed a symbol of classic style.

3.9 Health and Safety

The World Health Organization defines health as ‘a state of complete physical, mental and social well-being and not merely the absence of disease or infirmity’ [151]. Fontes et al. [19] explain that companies need to consider how their products may affect the health, well-being, and safety of a number of stakeholders including employees, consumers, and local communities. Weingaertner and Moberg [147] note that health impacts are among the core impacts that should be considered by any company. Health can be impacted by the pollution that is caused by petroleum production [136]. Because of flooding risks Brouwer and van Ek [100] explain that in the Netherlands one of the government’s primary policy concerns has always been building dikes so that residents of surrounding areas have safe and secure living conditions.

To be sure, one of the primary considerations of product impact is user and community safety. Street lamps are often installed to prevent crime, protecting pedestrians from potential harm [152]. The Spider Boot, a product designed to increase the distance between one’s feet and land mines, is intended for the prevention of physical harm ([153]). Cell phone (or smart phone) texting and driving has become a major safety concern that was not foreseen, but it has had a major unintentional negative impact on driver and pedestrian safety [154–158].

Products can also increase social and emotional well-being. Motorized wheelchairs increase intellectual and emotional development by allowing users to engage more fully with their community and surroundings [159]. On the other hand, products also have the potential to worsen

emotional well-being. One study found that electronic handheld devices could make users feel positive emotions such as excitement, satisfaction, and nostalgia. But when these products were difficult to use, the users were more likely to feel negative emotions such as frustration, annoyance, or disappointment, and these negative emotions lasted even after the users had stopped using the handheld device [160].

3.10 Human Rights

A product's impact on human rights includes the protection and promotion of rights that are presumed to apply to everyone. Human rights that have been identified by the Office of the United Nations High Commissioner for Human Rights (OHCHR) include

civil and political rights, such as the right to life, equality before the law and freedom of expression; economic, social and cultural rights, such as the rights to work, social security and education, or collective rights, such as the rights to development and self-determination, are indivisible, interrelated and interdependent. [161]

Human rights issues come into question for Weingaertner and Moberg [147] in the context of labor — specifically, forced labor and child labor.

Products may present opportunities or barriers for disadvantaged groups. Products may be designed to improve accessibility for those with physical disabilities. Motorized wheelchairs, prosthetic limbs, and curb ramps enable those with disabilities to interact with their community, pursue employment, and pursue many opportunities for mobility afforded to those without disabilities [142, 159, 162–166]. Or, the Transcontinental Railroad in the United States provides an example of how a product or technology can infringe on human rights. When railroad lines were built, they often crossed onto Native American territory. This westward expansion illustrates a disregard for land rights of Native American and led to forced displacement and the formation of reservations. But it also had deleterious effects on their lifestyle, and was accompanied by 'little sympathy for the preservation of a way of life that left farmlands unturned, coal unmined, and timber uncut' [167].

3.11 Social Networks and Communication

New products may impact social ties between individuals in a number of ways, such as the formation of new relationship [122] or increasing or decreasing the strength of the relationship. Donner [120] suggests the use of cellphones has allowed families to maintain strong relationships when members are living apart or when one moves away for work, which helps keep individuals and communities united ([145]). Advances in transportation technology and travel opportunities can foster more social connections between different geographical areas [103]. Or, communities with influx or outflow of residents may lead to the disruption of established relationships [97, 109].

Technologies have greatly enhanced communication and interaction with others over long distances. ICTs such as email, social networking sites, and instant messaging and video apps prove invaluable for maintaining connections to geographically dispersed friends, family, and acquaintances. Hampton and Wellman's [168] study of a neighborhood in a Toronto suburb demonstrates that residents with high-speed internet access either maintained or increased contact with distant friends while contact decreased for residents with no internet connection. Studies that have been discussed above show that increased mobile phone use in developing countries allows for family members to remain connected over long distances [120], and increased use of email in the workplace reduces face-to-face communication between coworkers [122]. Research suggests that products themselves can change how communication is carried out. Experiments with online communication show that those who use internet chat and discussion boards express higher confidence and comfort in expressing ideas, which facilitates the expression of different ideas [169]. Applications that allow face-to-face communication over long distances, such as video chat, can also influence the quality of communication. Video chat has been found to create a greater sense of emotional closeness between couples living long distances apart compared to audio-only forms of communication [170].

3.12 Conflict and Crime

Conflict includes activities that go against formal and informal rules within the community as well as conflicts between individuals [19, 171, 172]. Okeagu et al. [136] indicate that conflict in the Niger Delta is common as oil and gas companies actively seek to impose their will on local

communities, using violence in some instances. As a result, local citizens may resort to violence as a way to get back at the companies. More modest forms of conflict may also result. Garton and Wellman [122] report that with increased use of email in the workplace, coworkers tend to be more conflictual in their communication. Groups communicating via email tend to be more polarized and take longer to reach consensus. Nevertheless, the email conversations gave voice to more diverse opinions that may lead to better decisions overall.

Engineered products also have the potential to reduce crime. In reviewing crime deterrence principles and their applications, Hoffmann [173] explains that the Los Angeles Police Department installed physical barriers in a number of through-streets to make getaways following drive-by shootings more difficult. The installation of these barriers was meant to increase the perceived cost associated with engaging in this behavior. Indeed, shootings in these areas drastically decreased. Research also demonstrates that Closed Circuit Television (CCTV) cameras used for monitoring activity in public spaces is associated with a moderate reduction in some type of crime such as robberies [174–177]. Ratcliffe et al. [178] evaluated the use of CCTV cameras in high crime areas in Philadelphia and determined that their use was largely responsible for a 13% reduction in observed crime. Improved lighting in public spaces through street lamps, for instance, has been shown to reduce both crime and the fear of crime [179–181].

3.13 Cultural Heritage and Identity

Cultural heritage is the expression of the ‘ways of living developed by a community and passed on from generation to generation, including customs, practices, places, objects, artistic expressions and values’ [182]. This represents an emerging theme in the social impact assessment scholarship [109, 183] in which products are typically viewed as having negative impacts. Culture can be negatively impacted through, for instance, loss of language, defilement of culturally sacred sites, or violation of cultural taboos [17].

Cultural heritage takes many years to develop, but it can be disrupted in a relatively short period of time [184]. An example comes from Wheatley [145] who reports that mercury pollution negatively impacted Aboriginal communities in Canada in the 1970s. Residents on native reservations were forced to decrease their fishing activities and fish consumption significantly. Fishing, however, was ‘part of their cultural identity’ in which everyone had a role and where traditional

skills were passed on' (p. 87). Wheatley reports that a host of other negative outcomes accompanied the disruption of the traditional way of life in these communities including increased crime, violence, and suicides. Similarly, the transcontinental railroad challenged the Native American way of life by seeking to exterminate bison herds that local indigenous populations hunted and relied on. As part of the railroad expansion westward the US Army often sponsored hunting expeditions for private hunting parties to kill buffalo [185].

Transportation technologies may bring new or temporary residents that may not hold the same cultural values as the local residents, or their presence may strengthen the way local residents perceive or portray themselves. The transcontinental railroad changed the culture of Salt Lake City, Utah, during the latter half of the 1800s [105]. The expansion of the railroad brought new settlers and tourists to this city, which was previously intended to be a religious haven for Mormon pioneers who settled there to escape persecution experienced elsewhere in the Eastern and Midwestern United States. As outsiders came to Salt Lake City, the culture of the city began to change. Instead of trying to remain isolated and insulated from outside influences, over time the original settlers sought to present themselves as educated and civilized. And as they did, Mormons 'ultimately affected the way they conceived themselves' (p. 376). Instead of trying to maintain a separate existence and identity, they came to exemplify some of the same social, educational, and economic values shared by 'the elite classes of American Society' (p. 376).

Products may also serve to preserve cultural heritage by preserving the memory and physical spaces of sacred sites or by making such places more accessible to community members. ICTs including digital photogrammetry, laser scanning, and other digitization technologies can assist in the creation of materials that preserve visual displays of cultural sites, photographs, or language. Specifically, digital photogrammetry products have improved the recording of cultural heritage sites [186]. Additionally, R  ther et al. [187] explain, the use of laser scanning can provide a permanent record of a cultural artifact or site to be preserved for future generations to observe.

3.14 Conclusion

The purpose of this paper is to review and integrate research from a wide range of social science and engineering disciplines to provide a more informed inventory of social impacts compared with past work that includes lists of social impacts that are derived from authors' perspectives

or intuition. We believe this is an important step toward building a cumulative trajectory of work in this area. We also call for more work in this area to validate which social impacts are most relevant and under what conditions. A fruitful avenue for empirical research should, then, leverage experimental methods or examine product adoption in a number of settings to develop a more complete picture of whether certain consequences are broadly applicable or context-specific. To date, scholarship largely consists of case studies that identify product consequences, but insufficiently considers whether adoption may yield similar results in other settings. While instructive, this research typically ‘selects on the dependent variable’ by making few, if any, attempts to compare different elements of the social environment or different social environments that are affected by products and their features. Additionally, leveraging experimental methods will help researchers in distinguishing between the social phenomena that influence the antecedents of adoption compared with the outcomes or impacts that result from product use. Gender roles may not only be impacted by products, but they may influence who is likely to use a product in the first place.

In this paper, we follow other scholars who have attempted to integrate impact assessment categories in one place [188, 189]. While such integration is often beneficial, recent studies of impact assessment suggest that the inclusion of too many factors presents challenges. Integrated frameworks may present too much complexity and in fact overburden or even weaken assessment efforts. Or, integrated approaches may exacerbate tensions that exist between balancing social, environmental, and economic considerations such that one of those considerations comes to the fore while the others fade into the background. Similarly, the addition of new social impact categories to assessment efforts may draw attention away from existing categories or a methodology’s intended emphasis on a specific impact [190, 191]. Integration has been most successful when it is balanced enough to benefit the project without adding unnecessary complexity [191]. In considering the summary of social impacts and processes we have provided, we encourage researchers to thoughtfully and appropriately weigh each of the various measures into their own efforts.

A limitation of our paper, in particular, is the incomplete list of potential social impacts and processes we have identified. We could imagine a number of additional social phenomena that are shaped by product use. Religious practice and spirituality could be directly impacted by technology that enhances communication between believers or indirectly impacted by providing competing demands on believers’ time and attention. Social justice could be impacted by ICTs that

spread empowering knowledge and ideals, analogous to when the invention of the printing press delivered the Bible to the masses. Domestic violence can be addressed by users of technologies like the smart phone application Aspire, which is disguised as a news app but allows users to send a covert message to a trusted friend or contact. Technology could also affect communities' ability to respond to tragedy as well as community efforts to rebuild and move past such tragedies. No doubt there are other significant impacts for products that we did not identify in our paper. Discovering additional relevant impacts and social change processes constitutes another promising avenue for future research, considering that new technologies are increasingly introduced into the global marketplace. Therefore, the categories identified in our paper necessarily should be revised and improved for future use.

Of course, research on social impacts has many practical implications. The primary goal of this strand of research is to generate products that improve individuals' everyday lives, especially products for groups who are disadvantaged or in need of help. To this end, we believe that engineers can use the categories we have identified in this paper, as well as lists that have been generated in prior research [17–19], to design products with the end-user in mind as a way to gain a better understanding of the social benefits of their products. These categories could be used to inform a variety of methods for discovering and assessing the social impacts of an engineered product, such as Life Cycle Assessment or IDEO's Human Centered Design. As shown in our paper, design of seemingly innocuous features that accompany the use of common, everyday products, represents a significant need and can have a significant effect. But until these social impacts are named and evaluated, a greater awareness by researchers, designers, and users of these products will remain out of reach.

CHAPTER 4. SOCIAL IMPACT IN PRODUCT DESIGN, AN EXPLORATION OF CURRENT INDUSTRY PRACTICES

4.1 Introduction

Literature and historic research show a long tradition of analyzing the economic and environmental impacts of designed products, yet there is a lack of data and resources related to social sustainability — a pattern within the engineering field that will need to change in order to address new and evolving challenges facing society [192]. Engineers stand in position to pioneer best practices in accounting for a holistic view of sustainability, where “Sustainability Engineering is poised to propel the industry into a future that combines permanence, profitability, as well as livability” [20]. As engineers design with all aspects of sustainability in mind, they are likely to create effective and desirable products while also influencing the world’s economic standing, environmental state, and social well-being. While the former two are well researched in the realm of engineering design, social well-being is yet to be as thoroughly discussed in academic literature [193]. The value of these methods, however, is valuable to engineers to more fully inform their design decisions [194]. Though designing engineered products and systems from a social well-being perspective is an emerging topic in *literature*, this paper seeks to understand to what extent designing for social impact is found in *common industry*. The goal is to understand how those who design products consider the social impacts of those products. In this paper, the terms engineer and designer will mean those who have a significant role in defining and designing a product, structure, or industrial process.

4.1.1 Overview of Sustainability

As defined by the 1987 Brundtland report, sustainable development is “to ensure that it meets the needs of the present without compromising the ability of future generations to meet their own needs” [1]. In many cases this has been broken into the three pillars of sustainability which

are economic, environmental, and social impacts [5, 6]. By empirically researching how engineers and designers consider this sustainability, the benefits can be increased as a better understanding of social impact within sustainable design is defined.

4.1.2 Assessing the Social Impact of Products

Social impact refers to the effect that an engineered product has “on the day-to-day quality of life of persons” [14]. Specifically, the research of this project centralizes on the social impacts identifiable at the product use level. Beyond the scope of this study is the social impact an organization produces throughout the supply-chain of a given product or the programs instituted for community outreach.

This understanding of social impact establishes the purpose of this study, which is to determine the current standing of social impact design and assessment within the engineering and product design sector. To address this subject, work conducted by an interdisciplinary team of researchers from the Mechanical Engineering and Social Science disciplines provide initial findings on the current practices of engineers in product design for social impact through the use of interviews with industry professionals. The goal is *not* to review the state of the art in social impact design, but to simply understand the degree to which common engineers currently consider the social implications of their designs. While social sustainability research may be lagging behind economic and environmental sustainability, current practices within the engineering field can prove that social sustainability is being increasingly accounted for.

4.2 Literature Review

Recent work by the authors seeks to develop a holistic picture of what the current state of social impact is for product design. A three tier approach has been implemented to gain a wide breadth of understanding on this topic. These tiers include a review of 1) the literature [195], 2) products in use [196], and now 3) industry practices. Each of these viewpoints together provide insight beyond what a single approach would give. Understanding current industry practices is particularly interesting because there are likely differences between what is published by academics and what practicing engineers actually do [197]. To this end, the current paper is one step towards

understanding the gap between academic literature and industry practice on the topic of social impact modeling in product design. In addition, this paper seeks to provide a baseline understanding for what is most common among practicing engineers in regards to considering the social impact of their products.

4.2.1 Engineering Design & Social Impact in Academia

The literature provides processes and methods for engineers and other stakeholders to use when *evaluating* the social impact of their products [45, 198]. This includes methods such as Social Impact Assessments (SIA) [87, 199], as well as Social Life-Cycle Assessments (SLCA) [90, 200–202], however, the challenge may be in the usability of these processes [203]. Concerns have risen that social sustainability is not given as high a priority as economic and environmental sustainability [204]. An additional concern is that most measurements are not comparable across products. Work has been done towards developing metrics that may show quantifiable insights regardless of the product type or industry [13]. Others have become concerned with tools relying too heavily on biases and that systematic errors may be influencing the accuracy of these methods [205]. Some methods show promise but may be limited in scope to just the manufacturing and supply chain of products [206].

Less discussed in literature are methods for *predicting* social impact in early design stages [207]. This is of particular importance because the decisions made in the product design stage are said to influence 80% of sustainability impacts [208]. The processes that do exist focus on full sustainability, which includes not only social impacts, but economic and environmental as well [209, 210]. Even these contributions acknowledge the need to improve design tools for social impact prediction.

While most methods seek to characterize the impact a product has had from gathering historical data of the product in use, there are very few tools available to assist in predicting impacts and informing engineers/stakeholders before production. The literature in this area may not be as developed as other disciplines in engineering, but some resources are available to practicing engineers if they desire it [87, 90, 199–202].

There are methods, such as ethnography, that try to understand the target population prior to product design [211]. Additionally, Chen et al. developed a tool to more effectively consider

multicultural factors in new product development [212]. These methods are well developed, but there is no consideration to how widely they are adopted in industry.

A foundational study to this paper is provided by Rainock et al. [195]. Rainock et al. establishes 11 social impact categories specifically for products. These categories are developed through a literature survey aggregating Social Impact Assessment studies, empirical studies, and other studies that provide similar lists. This paper utilizes these 11 categories as a basis for the broad spectrum of potential social impacts a product may have on a person or community. These social impacts include: population change; family; gender; education; stratification; paid work; health & safety; human rights; social networks & communication; conflict & crime; and cultural heritage & identity [195].

4.2.2 Social Impact in Industry

Only a few have published details regarding the penetration of these social impact processes into industry. Garay and Font show that social responsibility is becoming more important in today's business environment, but many say budget constraints appear to prevent them from participating fully [213]. Jørgensen et al. looked at the feasibility of SLCA from a company's perspective showing that companies lacked a "resource-efficient" process that could look solely at the use stage of their products. Short et al. found that companies in Europe show great interest in designing for sustainability but lack the knowledge of how to best implement it [26]. Many methods discuss industry methods to sustainability but focus only on tools to consider environmental impacts. Kalish et al. do work to understand the state of methods considering full sustainability (including social) in industry, they acknowledge a focus in their work on environmental sustainability because industry is directing most of its efforts there [214].

4.2.3 Observations from the Literature Review

While significant efforts appear in the literature for considering social impact in general, there appears to be limited tools for applying it to product development and design. Additionally, most tools seek to only evaluate an impact that has already occurred instead of trying to predict the social impacts that may result. This area of prediction is especially important to product engineers

who have many design decisions to make before moving towards prototyping or launch. In this paper, we seek to understand what tools, if any, exist and are in use by industry professionals to either evaluate or predict the social impacts of their products. We do this through the use of in-depth interviews with current engineers working in industry. Section 4.3 outlines the method used for engaging in these interviews while section 4.4 reports on the results.

4.3 Methodology

Aligning with the goal to gain a deeper empirical understanding of the role social impact takes within the sphere of product design, empirical studies were conducted that utilized social science research methods to collect and analyze data on products created within the engineering sector.

4.3.1 Research Design

This empirical study centers on interviews conducted with 46 professionals who design products in various industries within the United States. The following process was followed to build the research strategy:

1. Develop initial research topics
2. Identify and contact industry professionals/companies for interviews
3. Conduct interviews
4. Transcribe and code interviews
5. Analyze codes and identify common themes

The initial discussion topics of the interviews constituted the extent to which engineers and product designers considered social impacts in the design process, which social impacts they considered, and whether they have procedures in places for measuring, predicting, and evaluating those social impacts among end users. Prior to the interviews, the following research topics were constructed:

1. Discover if companies have processes in place to consider the social impacts of the engineered products they design.
2. Evaluate whether engineers consider social impacts other than those that have a direct negative health and safety impact.
3. Discuss the tools that engineers have to measure the social impact of their designs.
4. Of the tools available, understand if they are applicable across industries or only useful for measuring specific social impact types.

The use of in-depth interviews was employed as the preferred research method for exploring these topics [215]. As is common within qualitative research, the use of typical case sampling was employed when creating the sampling frame of the study [216]. With this type of purposive sampling, emphasis was given on treating each interview as a unique case that informs the ultimate research topics [217]. Direct effort was given to find cases that represented various sectors, company sizes, and industries among the organizations contacted and selected for an interview.

A variety of organizations fall within the product engineering and design sector, of which this paper is interested in. In order to represent this variety, special attention was given to identifying specific organizations from a wide variety of industries. Included among the companies contacted were organizations that produce products related to the following industries: agriculture, construction, consulting, consumer products, defense, industrial, infrastructure, manufacturing, medical, mining, software, transportation, and water. The only criteria that was common among all participants is that they were currently, or had in the past, worked full-time as an engineer or designer to define a product, process, or structure. 37 of the participants were educated in an engineering field while 29 of those were specific to mechanical engineering. Other fields include industrial design, architecture, chemistry, biology, business management, and information systems.

A conscious effort to provide a national perspective was maintained, although 19 of the 34 companies identified for interviewing were located in Utah due to proximity to the researchers. An additional 7 companies were located in California and Michigan had 4. Other states include Illinois, Indiana, Massachusetts, and New York. When in-person interviews were not feasible, phone interviews were conducted instead.

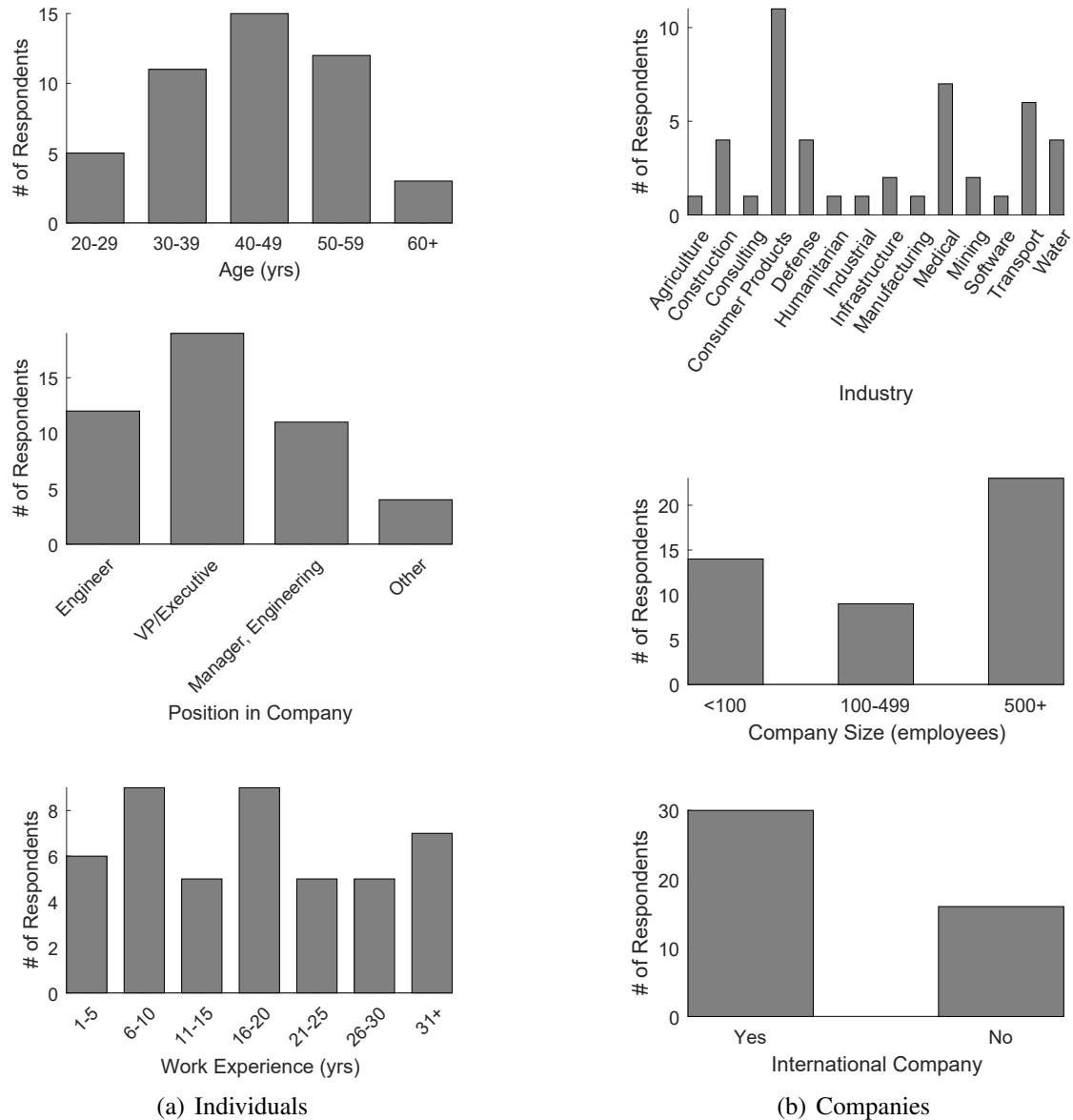

Figure 4.1: Demographics of participating individuals and companies

46 interviews were conducted over the course of eighteen months and were then analyzed according to the proposed methodology. Figure 4.1 shows demographics for individual respondents and their companies. This sample of 46 individuals represents a diverse set of professionals/industries and is adequate to begin exploring our research topics.

Though random sampling was not employed within the context of this study, the practices of generalization is not beyond the scope of the project. Just as is best practice within qualitative research, findings can lead to logical rather than statistical generalization [218]. It is assumed that the

cases and individuals presented within this study are typical of engineers and designers throughout the sector and their shared experiences are valuable contributions to the ongoing conversation centered on the role social impact assessment plays within the field of product design.

4.3.2 Procedure

Each interview, whether conducted locally or remotely, was directed by the use of a set interview guide. Emphasized in the interview guide were subtopics that addressed each research topic specifically. The two conductors of the interviews were encouraged to use the interview guide not as a rigid lineup of questions but rather as a tool to direct the conversation. Though the order of subtopics and connected questions were left to be decided upon by the interviewer, stress was given to address each point at some point throughout the interview in order to maintain consistency across the interviews. Interviews were audio recorded and lasted 30 minutes, on average, with some being as short as 20 minutes and a few lasting over an hour.

Interview questions were formatted in such a way as to include open-ended questions about how individual engineers and the organizations they have worked for navigated considering, designing for, and assessing social impact. In particular, open-ended questions were presented that required the interviewee to consider if their product influenced such social impact categories as described by Rainock et al. [195].

Once the interviews were conducted, transcriptions of the interviews were completed by both interviewers as well as through outsourcing to a transcription service. After the transcription process was finalized for each of the interviews, the two interviewers began the coding process [219].

Initial coding of each interview followed an open coding method. Here, various themes began to surface in relation to the research topics. The researchers allowed findings to emerge from the coding process itself rather than code strictly to prior-identified themes. This left the process open to unexpected findings and themes. Once repeated themes were initially identified from the open coding process, the researchers began employing the axial coding method to better define the emerging themes [220]. In all, just under 10,000 unique coded segments were analyzed.

The final method used during this step of the procedure was selective coding [221]. To avoid bias, two researcher coded each interview looking for separate sets of codes. Through-

out each interview the main distinguishable themes apparent from the previous two coding steps allowed the researchers to focus in on concepts and findings tailored to the research [222]. In connection with the selective coding process, specific effort was directed towards identifying strong examples for select themes that effectively represented the findings of the research.

4.4 Results & Discussion

The following sections are segmented by each research topic with an accompanying section for the results related to that topic. Immediately following the results is a brief discussion for each topic regarding the findings with observations from the interviews.

4.4.1 Research Topic 1

Discover if companies have processes in place to consider the social impacts of the engineered products they design.

Results:

This research topic considers if companies have processes in place to consider the social impacts of the engineered products they design. 95.6% of the interview respondents answered affirmatively when asked if they consider the social impacts their products will have when designing them. It turns out the majority of companies interviewed do have some processes in place to consider the social impact of their products.

Discussion:

This is overwhelming evidence showing that engineers do have some processes to consider the social impact of their products. The nature of this topic required a binary response of if the company does or does not have at least one process to consider social impact. That is to say, 95.6% of the respondents consider social impact at least to some extent, while it will be shown in further discussions that simply the existence of a process rarely equates to a rigorous consideration of social impact.

Despite varying levels of consideration, the fact that nearly all respondents are concerned about the social impacts of their products is very promising for the field of sustainable design. The field will most likely only become more centralized as corporations, stakeholders, and consumers begin to demand socially responsible practices. A further discussion of the types of processes used by these companies is found in section 4

4.4.2 Research Topic 2

Evaluate whether engineers consider social impacts other than those that have a direct negative health and safety impact.

Results:

An extension of topic 1 is that if social impacts are considered, it is only those that have a direct health or safety impact. This second research topic allows a deeper analysis of the interviews and shows to what extent the full breadth of social impact is being considered. When asked what impacts they considered, respondents would offer several different categories from a list of options provided. This list consisted of the 11 social impact categories developed by Rainock et al. [195]. Every respondent identified at least two separate impact categories while most respondents identified more. Despite bringing up many different types of impacts, however, the general focus of their conversation remained on health and safety.

Figure 4.2 depicts, by word count, the amount each impact category was discussed as a percentage of all impact category discussions. This figure reveals that 35.6% of social impact category conversations were focused on health and safety, with the next most discussed topic being employment at 11.6%. This means that respondents are almost three times more likely to talk about the health and safety impacts of their products over any other impact the product may have. Alternatively, the least discussed impact category is population change (technologies that assist or cause migration in/out of a geographic location) at 2.4%.

When the data behind Figure 4.2 is explored more deeply, a disconnect begins to appear between front-line engineers, engineering managers, and executives. The data as shown in Figure 4.3, shows that executives spent more of their conversations discussing other impacts instead

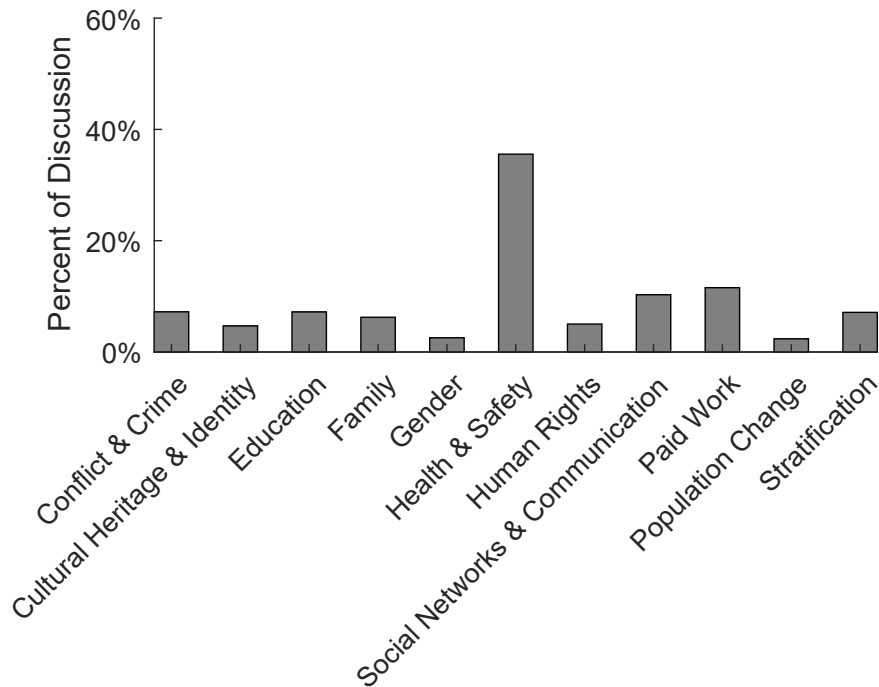
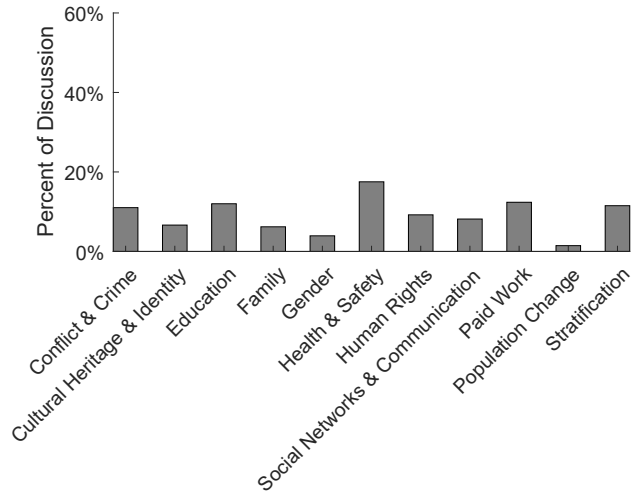

Figure 4.2: Percent of social impact considerations in each category

of focusing so heavily on health and safety. The standard deviation of the impact category percentages when filtered for just the responses of executives (Fig 4.3(a)) is only 4.5% . Conversely, the engineer appears to more heavily emphasize health and safety considerations. The standard deviation of the impact category percentages relating to the engineers (Fig 4.3(c)) is 13.3%. The response for managers appears to be a mix of both engineers and executives, not as irregular as the engineers, but also not as consistent as the executives. The standard deviation for manager's impact category percentages (Fig 4.3(b)) is 10.1%. Figure 4.4 plots the standard deviation of the data for each position mentioned above.

Discussion:

An under-emphasis on impacts outside of health and safety could be occurring because either these impacts are more recognizable than any other, or the engineering tools to consider it are well developed and generally accepted. Respondents agreed that impacts regarding health and safety are regulated by governments and industry standards more heavily than any other category, which may have an impact on a company's responsibility to consider it. Additionally, the role of



(a) Executives

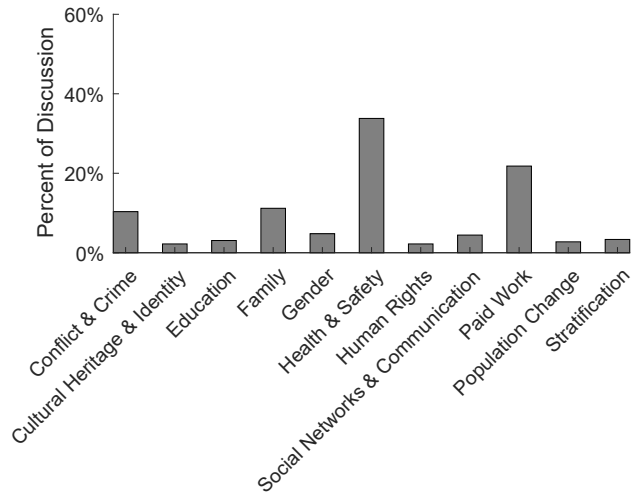

(b) Managers

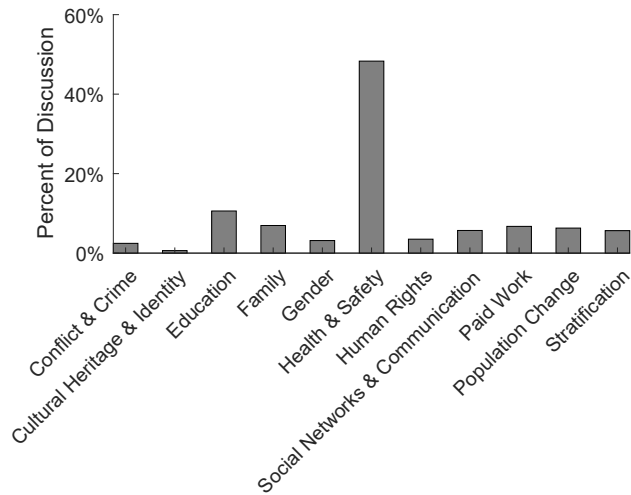

(c) Engineers

Figure 4.3: Percent of social impact considerations segmented by job title

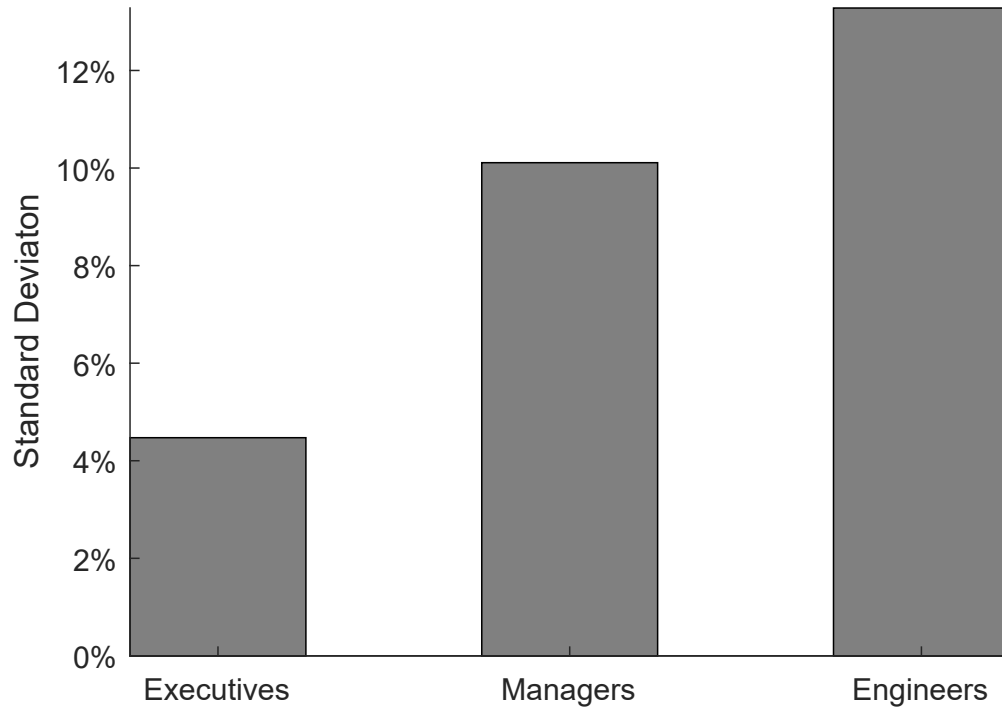

Figure 4.4: Standard deviation of percent of discussion (for social impact categories). This data is separated by what position the respondent holds in their company.

a professional engineer is often to ensure designs for products, systems, and structures are safe which may cause other impacts to be under emphasized.

Regardless of why responses focused on health and safety, nearly all products have far more impacts than this. For example, the impact of home appliances on gender stereotypes and family relationships is well documented [195]. It is true that home appliances such as electric irons, gas-powered ovens, and washing machines can have serious safety implications if carelessly designed, but tools and discussions to help consider impacts on gender stereotypes and family relationships may have helped discover alternative designs as well. Additional processes need to be developed in order to bring more balance to the under-served categories, such as population change, gender, or cultural heritage & identity. This may help engineers understand the full scope of possible impacts their product may have.

Executives tend to have a more holistic view of what impacts are important to their company with a standard deviation of almost a third of the size of the engineers data. The disconnect between upper level management and their engineers is evident in the data. The hierarchical structure that is commonplace in many well-established companies may be diluting the vision and goals

by the time it reaches the engineers. Removing the health and safety category from the engineer's data reveals how emphasized it is as the standard deviation for engineers drops to 2.8% in this scenario. Standard deviations for all three segments without health and safety data can be found in Figure 4.5.

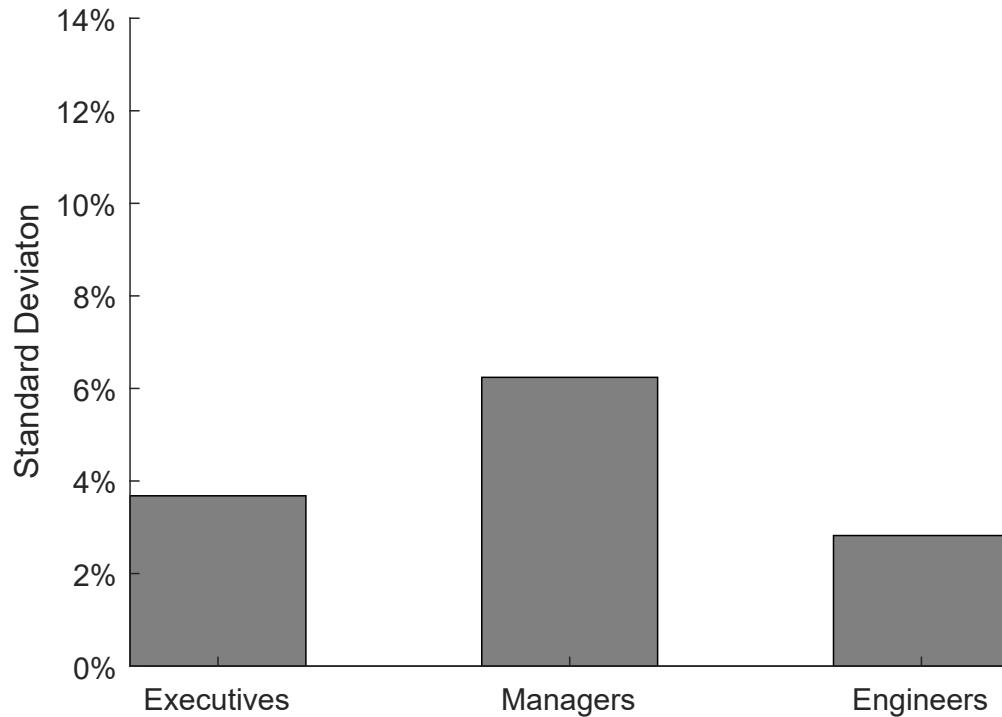

Figure 4.5: Standard deviation of percent of discussion (for social impact categories) with the health and safety data removed. This data is separated by what position the respondent holds in their company.

4.4.3 Research Topic 3

Discuss the tools that engineers have to measure the social impact of their designs.

Results

This topic seeks to understand if engineers have tools to measure the social impact of their designs. All the processes discussed in the interviews were categorized as either “aable” or “non-measurable”. If the process had a clear quantifiable value as an output then it was considered

measurable. Figure 4.6 shows the proportion of measurable to non-measurable processes discussed by the respondents.

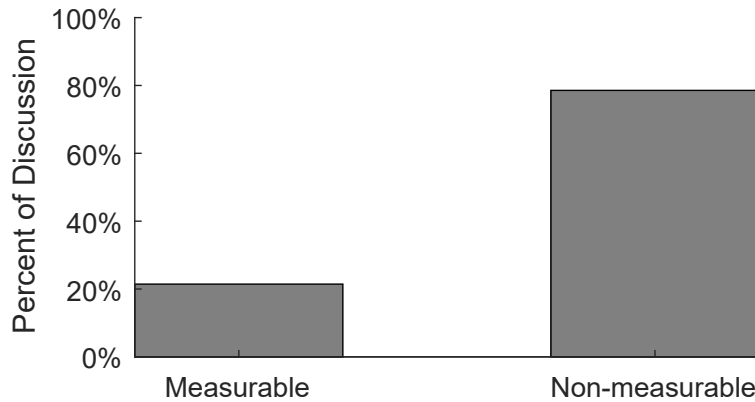

Figure 4.6: Proportion of all processes discussed by respondents that are measurable or non-measurable

78.5% of the discussion on processes were regarding unquantifiable processes. Most common among those that were measurable were checklists and Design Failure Modes and Effects Analysis (DFMEA), which is a common tool to consider the safety of a given product [223].

Discussion

This furthers the dialog that engineers have insufficient means to understand and predict the impacts of their products. In most cases, the non-measurable processes required a large amount of intuition in order to determine if the breadth and depth of the impact consideration was sufficient.

4.4.4 Research Topic 4

Of the tools available, understand if they are applicable across industries or only useful for measuring specific social impact types.

Results

This topic considers of the tools available, are they applicable across industries or do they only measure specific impact types? While many respondents showed great enthusiasm for the

types of social impact they consider, the data uncovers a surprising lack of coverage with their processes. Figure 4.7 shows that the majority of conversations about what specific processes were used resulted in a discussion regarding a lack of processes. “Lack of Process” accounted for 53.6% of the discussion with industry specific processes taking 25.8%. “Industry Specific” processes are ones that are considered too specialized to be useful outside of that industry. Checklists and DFMEA may be industry agnostic, but they combine for only 20.7% of the processes discussed. Most checklists were developed within the company to ensure compliance with government regulations.

Discussion

This informs topic 4 as the majority of processes discussed are only usable in the respondent’s specific industry. Additionally, while checklists and design failure modes and effects analysis (DFMEA) are also used, only DFMEA arrives at a quantifiable value potentially useful in cross product/industry comparison. Even some of the most common social impact processes found in literature (SIA, SLCA) are not found among the list practices currently applied by engineers to products in industry.

This is a common problem for those desiring to quantify social impacts. To relate this to other pillars of sustainability, there are no measurements for social issues similar to dollars for economic issues, or CO_2 emissions in environmental impacts. Whether a measure such as this is desirable or useful for social impact is beyond the scope of the current paper. The lack of a widely accepted measurement causes difficulty in comparing true impact of a product both positively and negatively.

The difference between predictive and evaluative processes was an important distinction for the interviews. Predictive processes were generally specific to an industry and had little value in comparison across different industries or even across different products within an industry. The exception to this was DFMEA which has been used extensively in design activities for years.

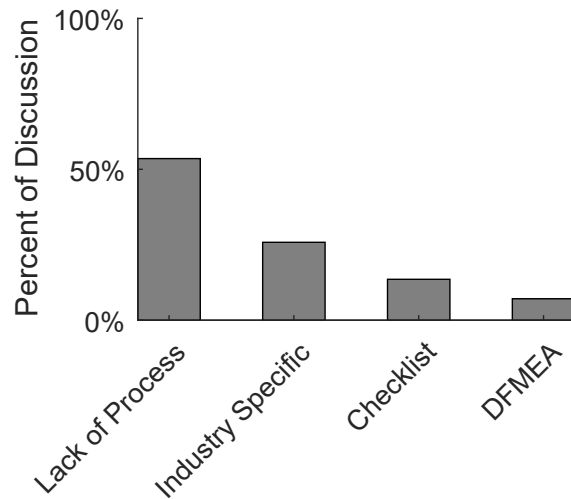

Figure 4.7: Proportion of conversation time spent on social impact processes

4.4.5 Additional Results: General Themes

Stepping away from the quantifiable results, there is also benefit to sharing anecdotal themes that emerged from the interviews. While each individual had differing perspectives regarding how designing for social impact should be carried out, nearly all respondents showed interest and excitement about the possibility of being able to do so better. The following four themes were found consistently throughout the interviews:

1. Individuals wish to do more in regards to designing for social impact, but are constrained by the need to win financially in the market place. Designers continually expressed a desire to design for social impact more, but said it simply wasn't feasible to expend the time and resources to do it properly. To their credit, each company typically had two or three main social impact categories in which they were aware of and at least discussed in design meetings. Where the lack of ability came was in being able to diagnose less common impacts and their products ability to affect those.
2. A corporate culture that prioritizes social impact considerations must come from the top leadership and then filter down. A direct quote from one of the interviews stated "it can also take... a uniquely insightful and courageous leader to put priority on something that increases cost, reduces the potential appeal of the product, [and] constrains the market around it". In

many cases the social mission is a part of the company mission which allows extra cost to be given in order to maintain the brand's image.

3. Professionals realize that consumers are increasingly demanding socially responsible products, which extends to the companies that sell them. Most interviewees brought this point up anecdotally. It was not clear if their direct consumers fell into this category, but the rise of benefit corporations and other movements appear to support this. The most common situation where this is true are for companies selling directly to consumers. In general, if a respondent didn't work in a company that designed products directly for consumers then it immediately became more difficult to find the value in designing for social impact. For those that did work in a consumer facing industry, many times the respondents would discuss social impacts from a marketing perspective, both in marketing message and other marketing research efforts the company had.
4. Companies who mainly operate in a business-to-business landscape find it harder to have the freedom to consider the social impact of their products. This builds on the item 3 as companies who designed products that were a part of a larger system, or used in another corporate or industrial setting, had even more difficulty justifying the costs associated with designing for social impact. Generally, they were constrained with simply meeting the contract for the least amount of cost. Again, most individuals expressed a desire to consider it more, but stated simply that the decision had to be left up to the client.

These themes point out the need for processes and tools that simplify and expedite the process of designing for the social impact elements of sustainability. The common constraint of cost and time is the reality that most companies operate in. To a company that does not specialize in social impact nor employs a social scientist to work with the product development team, an undertaking to characterize and predict the impact of their products would be daunting indeed. However, much can be done to communicate the value, facilitate the process, and improve the methods for designing for social impact so that any engineer can feel competent in doing so.

4.5 Conclusion

Current social and political trends may be causing more individuals to care about the social impacts of products, services, and regulations. Despite this, engineers appear to lack the necessary tools to consider the breadth and depth of possible impacts relating to their products. This is true in two ways; 1) design engineers do not equally consider the wide spectrum of impacts that their product could potentially have, and 2) the tools necessary to quantify the level of impact a product has are either non-existent or severely underdeveloped across industries.

From these interviews, it appears that intuition is the basis for most social impact related decisions. This may explain why engineering projects for the developing world often have difficulty, the engineers may be relying on intuition for a context they have little, if any, experience with. However, there are many high impact investors/philanthropists that depend on rigorous metrics for the humanitarian work they are involved in. Potential future work can also entail working with these organizations to bring some of the metrics and processes to other industries. Progress can be accelerated as proper tools and measurements are developed and made available to engineers in industry and not just in academia.

While it may be true that sophisticated processes exist to help engineers consider the breadth and depth of their product's social impacts, we can be skeptical about how widely adopted these processes are among practicing engineers. Even if there are a handful of companies out there with these processes in place, these interviews indicate that the majority of organizations likely have a desire to consider social impact more fully, but lack the necessary tools and resources to do so in a rigorous manner.

Processes designed for assisting engineers in considering social impact should be made more readily available to engineers in industry. If they are available and engineers choose not to adopt, then the current process should be altered to be more efficient and easy to use. Additional work can be done to help educate engineers and their leaders as the value of considering social impact in product design.

CHAPTER 5. CONCLUSION

5.1 Sustainability Design Space

Chapter 2 presented a 5-step process for finding and using the sustainability space to support sustainable design decisions. Having worked closely with the ideas presented herein, the following observations were made:

1. The identification and use of the sustainability space can bring new insights to decision making in sustainable design that may not be intuitively discovered otherwise. Its value is significant because it characterizes the tradeoffs between economic, environmental, and social impact – which are the three areas of sustainability our products will influence whether we explicitly evaluate it or not.
2. The nature of the sustainability space is too complex to characterize and understand by intuition alone. To an extent, this has stalled many sustainable design efforts over the past two decades, which has caused many to believe in the concept of sustainability but abandon fully pursuing it in practice.
3. While too complex to manage by intuition alone, sustainability can be decomposed into smaller more manageable sustainability issues that can be understood intuitively. This understanding can lead to simple mathematical models (for each sustainability issue) that can be invoked simultaneously in a computational setting to characterize the complex sustainability space.
4. Although the basis for the ideas presented in this paper center on the multiobjective optimization principle of Pareto optimality (or the principle of non-domination), no complex multiobjective optimization algorithm is *necessary* to generate the results presented in this

paper. In its basic form, very similar results can be achieved using simple monte carlo simulations and Pareto filtering. This is significant because it means that little-to-no experience in multiobjective optimization is needed to identify and use the sustainability space. On the other hand, using multiobjective optimization, the design team can guarantee that it has completely and rigorously identified the boundaries of the sustainability space.

These efforts do not come without their limitations. Weighting and aggregation may be the greatest limitation found within this model. Additionally, the social element of sustainability is still young in its development and as such there are no accepted methods for combining and assigning weights for these issues. Any design space characterization such as this is only as good as the models that are fed into it. Realizing the models surrounding social impact in product design were underdeveloped led to a refocused research effort, with a portion of the results of those efforts being reported in chapters 3 and 4.

5.2 Literature Survey

The purpose of chapter 3 is to review and integrate research from a wide range of social science and engineering disciplines to provide a more informed inventory of social impacts compared with past work that includes lists of social impacts that are derived from authors' perspectives or intuition. This is an important step toward building a cumulative trajectory of work in this area. From this, 11 social impact categories were identified in literature that may serve to more easily focus engineers on a broader range of impacts.

More work in this area would be beneficial to validate which social impacts are most relevant and under what conditions. A fruitful avenue for empirical research should, then, leverage experimental methods or examine product adoption in a number of settings to develop a more complete picture of whether certain consequences are broadly applicable or context-specific.

Chapter 3 follows other scholars who have attempted to integrate impact assessment categories in one place [188, 189]. While such integration is often beneficial, recent studies of impact assessment suggest that the inclusion of too many factors presents challenges. Integrated frameworks may present too much complexity and in fact overburden or even weaken assessment efforts. Or, integrated approaches may exacerbate tensions that exist between balancing social, environ-

mental, and economic considerations such that one of those considerations comes to the fore while the others fade into the background. Similarly, the addition of new social impact categories to assessment efforts may draw attention away from existing categories or a methodology's intended emphasis on a specific impact [190, 191]. Integration has been most successful when it is balanced enough to benefit the project without adding unnecessary complexity [191]. In considering the summary of social impacts and processes we have provided, it is encouraged that researchers thoughtfully and appropriately weigh each of the various measures into their own efforts.

5.3 Industry Interviews

Current social and political trends may be causing more individuals to care about the social impacts of products, services, and regulations. Despite this, engineers appear to lack the necessary tools to consider the breadth and depth of possible impacts relating to their products. This is true in two ways; 1) design engineers do not equally consider the whole spectrum of impacts that their product could potentially have, and 2) the tools necessary to quantify the level of impact a product has are either non-existent or severely underdeveloped across industries.

From the interviews in chapter 4, it appears that intuition is the basis for most social impact related decisions. This may explain why engineering projects for the developing world often have difficulty. The engineers may be relying on intuition for a context they have little, if any, experience with. However, there are many high impact investors/philanthropists that depend on rigorous metrics for the humanitarian work they are involved in.

Potential future work can also entail working with these organizations to bring some of the metrics and processes to other industries. Progress can be accelerated as proper tools and measurements are developed and made available to engineers in industry and not just in academia.

There are additional insights to be gained from the interviews beyond what is reported here. Topics that were discussed in interviews, and coded, but not analyzed in depth are enumerated below.

1. Identifying potential product social impacts beyond the 11 categories developed in chapter 3. A limitation of the interview process constrained many respondents to only discuss the 11 categories provided to them, however, additional impacts were discussed by the professionals

interviewed. Many of these were either environmental impacts or social impacts affected by the business model more than the company's products, but there are likely some that should be considered social impacts and evaluated whether they should be added to the list of 11 categories developed in chapter 3.

2. A more in-depth review of the processes used by engineers to consider social impact. This thesis took a high level analysis of those processes to understand if they are applicable across different industries as well as their measurability. A in-depth study to characterize these processes more fully could yield valuable themes to inform the future development of tools used for social impact design.
3. The role of government was also discussed in many of the interviews. The extent to which a company or individual considers social impact is often heavily correlated with the types and amount of regulations they are under.
4. Each respondent discussed both the value and the barriers they encounter while considering social impact in their products. High level conclusions to this topic are found in chapter 4. A more in-depth analysis of these responses could be inform future tool development for social impact design. It is not enough to develop tools that *can* be used for considering social impact, these tools are of little value if they are not *used* in practice. Ensuring that these tools capture the value and overcome the barriers may be an essential aspect for future development.

5.4 Final Observations

The work reported in this thesis is a significant step forward in being able to handle the unwieldy nature of social impact in product design in the larger context of sustainability. Not only do these efforts provide a basis upon which future tools can be developed, they are also immediately useful in providing a basic framework upon which to consider the full spectrum of social impact of products during design. As a basis for new tools, this effort is already underway in developing new metrics and methods to assist in social impact design [13].

As previously mentioned, this work can also be used immediately as a framework to begin considered social impact more fully in product design. The value of this has been validated in the interviews where it was observed that engineers tend to focus on only a small subset of impacts. The work in this thesis can be immediately useful for those engineers to simply open their minds to additional potential impacts that may need to be considered.

As more practical and applicable tools are developed to consider the social impact of products, designers will have the ability to design for these impacts as easily as they design for economic and environmental impacts now. The resources currently required to understand a product's social impact is a major inhibitor preventing engineers from evaluating and predicting it to the extent that they currently consider economic and environmental impacts. With new tools in hand, engineers can take a step forward in designing not only economically profitable and environmentally responsible, but also for the social well-being of people and communities throughout the world.

REFERENCES

- [1] Brundtland, G. H., 1987. *Report of the World Commission on environment and development: "our common future"*. Oxford University Press. 1, 5, 7, 63
- [2] Carrera, D. G., Mack, A., Gallego Carrera, D., and Mack, A., 2010. "Sustainability assessment of energy technologies via social indicators: Results of a survey among European energy experts." *Energy Policy*, **38**(2), pp. 1030–1039. 1, 56
- [3] Klöpffer, W., 2003. "Life-Cycle based methods for sustainable product development." *The International Journal of Life Cycle Assessment*, **8**(3), pp. 157–159. 1
- [4] Hauschild, M. Z., Dreyer, L. C., and Jørgensen, A., 2008. "Assessing social impacts in a life cycle perspective-Lessons learned." *CIRP Annals - Manufacturing Technology*, **57**(1), pp. 21–24. 1
- [5] Buchert, T., Neugebauer, S., Schenker, S., Lindow, K., and Stark, R., 2015. "Multi-criteria decision making as a tool for sustainable product development - Benefits and obstacles." *Procedia CIRP*, **26**, pp. 70–75. 1, 5, 7, 8, 64
- [6] Elkington, J., 2004. "Enter the triple bottom line." In *The Triple Bottom Line: Does it all Add Up?*, Vol. 11. pp. 1–16. 1, 64
- [7] Slaper, T., Hall, T., Triple, T., and Line, B., 2011. "The Triple Bottom Line : What Is It and How Does It Work?." *Indiana Business Review*, pp. 4–8. 1
- [8] Gacso & IEMA, 2015. *Defining Corporate Sustainability: A GACSP & IEMA white paper Tech. rep.* 1, 5
- [9] McDonough, W., and Braungart, M., 2002. "Design for the triple top line: new tools for sustainable commerce." *Corporate Environmental Strategy*, **9**(3), pp. 251–258. 1, 5, 8, 45
- [10] Cardinale, B. J., Srivastava, D. S., Duffy, J. E., Wright, J. P., Downing, A. L., Sankaran, M., and Jouseau, C., 2006. "Effects of biodiversity on the functioning of trophic groups and ecosystems." *Nature*, **443**(7114), pp. 989–992. 1, 5
- [11] Bermejo, R., 2014. "Circular Economy: Materials Scarcity, European Union Policy and Foundations of a Circular Economy." In *Handbook for a Sustainable Economy*. Springer, pp. 269–287. 1, 5
- [12] Garriga, E., and Melé, D., 2004. "Corporate social responsibility theories: mapping the territory." *Journal of business ethics*, **53**(1-2), pp. 51–71. 1, 5

- [13] Stevenson, P. D., Mattson, C. A., Bryden, K. M., and MacCarty, N. A., 2018. "Toward a Universal Social Impact Metric for Engineered Products That Alleviate Poverty." *Journal of Mechanical Design*, **140**(4), p. 41404. 2, 65, 85
- [14] Burdge, R. J., 2004. *A community guide to social impact assessment*. Social Ecology Press. 2, 45, 46, 49, 51, 64
- [15] <https://www.asme.org/wwwasmeorg/media/ResourceFiles/AboutASME/GetPublications/P-15-7-Ethics.pdf>, 2009. "Code of ethics of engineers." *American Society of Mechanical Engineers* Accessed: 2019-03-05. 2, 45
- [16] <http://ethics.iit.edu/ecodes/node/3296>, 2001. "Code of ethics." *Society of Manufacturing Engineers* Accessed: 2019-03-02. 2, 45
- [17] Vanclay, F., 2002. "Conceptualising social impacts." *Environmental Impact Assessment Review*, **22**(3), pp. 183–211. 3, 45, 46, 47, 48, 49, 59, 62
- [18] Epstein, M. J., and Buhovac, A. R., 2014. *Making sustainability work: Best practices in managing and measuring corporate social, environmental, and economic impacts*. Berrett-Koehler Publishers. 3, 45, 47, 51, 62
- [19] Fontes, J., Bolhuis, A., Bogaers, K., Saling, P., Van Gelder, R., Traverso, M., Das Gupta, J., Bosch, H., Morris, D., Woodyard, D., Bell, L., van der Merwe, R., Laubscher, M., Jacobs, M., and Challis, D., 2014. "Handbook for Product Social Impact Assessment." pp. 1–130. 3, 45, 47, 48, 56, 58, 62
- [20] Perl, J., 2016. *Sustainability Engineering: A Design Guide for the Chemical Process Industry*. Springer. 3, 63
- [21] Elkington, J., 1997. "Cannibals with forks." *The triple bottom line of 21st century*. 5
- [22] Howarth, G., and Hadfield, M., 2006. "A sustainable product design model." *Materials and Design*, **27**(10), pp. 1128–1133. 5, 7
- [23] Reuter, B., 2016. "Assessment of sustainability issues for the selection of materials and technologies during product design: a case study of lithium-ion batteries for electric vehicles." *International Journal on Interactive Design and Manufacturing*, **10**(3), pp. 217–227. 5, 7
- [24] Hahn, T., Figge, F., Pinkse, J., and Preuss, L., 2010. "Trade-offs in corporate sustainability: you can't have your cake and eat it." *Business Strategy and the Environment*, **19**(4), pp. 217–229. 5
- [25] Matar, M. M., Georgy, M. E., and Ibrahim, M. E., 2008. "Sustainable construction management: Introduction of the operational context space ({OCS})." *Construction Management and Economics*, **26**(3), pp. 261–275. 5, 11
- [26] Short, T., Lee-Mortimer, A., Luttrupp, C., and Johansson, G., 2012. "Manufacturing, sustainability, ecodesign and risk: lessons learned from a study of Swedish and English companies." *Journal of Cleaner Production*, **37**, pp. 342–352. 5, 66

- [27] Holden, E., Linnerud, K., and Banister, D., 2014. “Sustainable development: Our Common Future revisited.” *Global Environmental Change*, **26**(1), pp. 130–139. 7
- [28] Norman, W., and MacDonald, C., 2004. “Getting to the bottom of triple bottom line.” *Business ethics quarterly*, **14**(2), pp. 243–262. 8, 45
- [29] Brezet, H., Van Hemel, C., Böttcher, H., and Clarke, R., 1997. *Ecodesign: a promising approach to sustainable production and consumption*. {U}nited {N}ations {E}nvironment {P}rogramme. 8, 14, 43
- [30] Luttrupp, C., and Lagerstedt, J., 2006. “EcoDesign and The Ten Golden Rules: generic advice for merging environmental aspects into product development.” *Journal of Cleaner Production*, **14**(15), pp. 1396–1408. 8
- [31] Yuan, C. Y., and Dornfeld, D. A., 2010. “A schematic method for sustainable material selection of toxic chemicals in design and manufacturing.” *Journal of Mechanical Design*, **132**(9), p. 91014. 8
- [32] Telenko, C., and Seepersad, C. C., 2010. “A methodology for identifying environmentally conscious guidelines for product design.” *Journal of Mechanical Design*, **132**(9), p. 91009. 8
- [33] Goggin, P. A., 1994. “An appraisal of ecolabelling from a design perspective.” *Design Studies*, **15**(4), pp. 459–477. 8
- [34] Bhamra, T. A., Evans, S., McAlloone, T. C., Simon, M., Poole, S., and Sweatman, A., 1999. “Integrating environmental decisions into the product development process in the early stages.” In *Environmentally Conscious Design and Inverse Manufacturing, 1999. Proceedings. EcoDesign’99: First International Symposium On*, IEEE, pp. 329–333. 8
- [35] Goedkoop, M., Effting, S., and Collignon, M., 2000. *The Eco-indicator 99: A Damage Oriented Method for Life-cycle Impact Assessment: Manual for Designers*. PR{é} Consultants. 8
- [36] Al-Ghamdi, S. G., and Bilec, M. M., 2015. “Life-cycle thinking and the LEED rating system: global perspective on building energy use and environmental impacts.” *Environmental science & technology*, **49**(7), pp. 4048–4056. 8
- [37] Witczak, J., Kasprzak, J., Klos, Z., Kurczewski, P., Lewandowska, A., and Lewicki, R., 2014. “Life cycle thinking in small and medium enterprises: the results of research on the implementation of life cycle tools in Polish SMEs—part 2: LCA related aspects.” *The International Journal of Life Cycle Assessment*, **19**(4), pp. 891–900. 8
- [38] Walden, D. D., Roedler, G. J., Forsberg, K., Hamelin, R. D., and Shortell, T. M., 2015. *Systems engineering handbook: A guide for system life cycle processes and activities*. John Wiley & Sons. 8
- [39] Missimer, M., Robèrt, K.-H., Broman, G., and Sverdrup, H., 2010. “Exploring the possibility of a systematic and generic approach to social sustainability.” *Journal of Cleaner Production*, **18**(10), pp. 1107–1112. 8

- [40] Lofthouse, V., 2013. “Social Issues: Making them relevant and appropriate to undergraduate student designers.” *Design and Technology Education: an International Journal*, **18**(2). 8, 14
- [41] Garff, P., Dahlin, E. C., Ward, C., and Lewis, R., 2014. “Analysis of integrated engineering and social science approaches for projects in developing communities.” *International Journal for Service Learning in Engineering, Humanitarian Engineering and Social Entrepreneurship*, pp. 137–150. 8
- [42] Bhamra, T., and Lofthouse, V., 2007. *Design for sustainability: a practical approach*. Gower Publishing, Ltd. 8, 14
- [43] Tischner, U., and Charter, M., 2001. “Sustainable product design.” *Sustainable solutions: developing products and services for the future*, **117**(138), p. 22. 8
- [44] Acharya, T., and Others, 2008. *Design for Social Impact: A How-To Guide*. 8
- [45] Mattson, C. A., Wood, A. E., and Renouard, J., 2017. “Village drill: A case study in engineering for global development with five years of data post market-introduction.” *Journal of Mechanical Design*, **139**(6), p. 065001. 8, 20, 25, 28, 54, 65
- [46] Brezet, H., 1997. “Dynamics in ecodesign practice.” *Industry and environment*, **20**(1-2), pp. 21–24. 8
- [47] Erickson, L. E., Burkey, A., Morrissey, K. G., Reynolds, M., Robinson, J., Ronnebaum, B., Wagner, T., Singh, P., Natarajan, B., and Pahwa, A., 2016. “Social, Economic, Technological, and Environmental Impacts of the Development and Implementation of Solar-Powered Charge Stations.” *Environmental Progress and Sustainable Energy*, **34**(6), pp. 1808–1813. 8, 11
- [48] Deb, K., 2014. “Multi-objective optimization.” In *Search methodologies*. Springer, pp. 403–449. 9
- [49] Wu, J., and Azarm, S., 2001. “Metrics for quality assessment of a multiobjective design optimization solution set.” *Journal of Mechanical Design*, **123**(1), pp. 18–25. 9
- [50] Marler, R. T., and Arora, J. S., 2004. “Survey of multi-objective optimization methods for engineering.” *Structural and multidisciplinary optimization*, **26**(6), pp. 369–395. 9
- [51] Pareto, V., 1927. “Manual of Political Economy.”. 9
- [52] Messac, A., 2000. “From dubious construction of objective functions to the application of physical programming.” *AIAA Journal*, **38**(1), pp. 155–163. 9, 35
- [53] Pandey, V., Mourelatos, Z. P., and Nikolaidis, E., 2013. “Limitations of Pareto Front in Design Under Uncertainty and Their Reconciliation.” *Journal of Mechanical Design*, **135**(7), p. 71010. 9
- [54] Das, I., and Dennis, J. E., 1997. “A closer look at drawbacks of minimizing weighted sums of objectives for Pareto set generation in multicriteria optimization problems.” *Structural optimization*, **14**(1), pp. 63–69. 9, 17

- [55] Messac, A., and Mattson, C. A., 2004. “Normal constraint method with guarantee of even representation of complete Pareto frontier.” *AIAA journal*, **42**(10), pp. 2101–2111. 9
- [56] Farid, A. M., and Suh, N. P., 2016. *Axiomatic Design in Large Systems: Complex Products, Buildings and Manufacturing Systems*. Springer. 10
- [57] Qureshi, A. J., Eisenbart, B., Dantan, J.-Y., and Blessing, L., 2013. “Design Automation with the Characteristics Properties Model and Property Driven Design for Redesign.” In *Smart Product Engineering*. Springer, pp. 563–572. 10
- [58] Malmiry, R. B., Dantan, J.-Y., Pailhès, J., and Antoine, J.-F., 2016. “A product functional modelling approach based on the energy flow by using characteristics-properties modelling.” *Journal of Engineering Design*, **27**(12), pp. 817–843. 10
- [59] Du Pont, B. L., and Cagan, J., 2012. “An extended pattern search approach to wind farm layout optimization.” *Journal of Mechanical Design*, **134**(8), p. 81002. 10, 11
- [60] Antipova, E., Boer, D., Cabeza, L. F., Guillén-Gosálbez, G., and Jiménez, L., 2013. “Uncovering relationships between environmental metrics in the multi-objective optimization of energy systems: A case study of a thermal solar Rankine reverse osmosis desalination plant.” *Energy*, **51**, pp. 50–60. 10, 11
- [61] Shahi, S. K., Wang, G. G., An, L., Bibeau, E., and Pirmoradi, Z., 2012. “Using the pareto set pursuing multiobjective optimization approach for hybridization of a plug-in hybrid electric vehicle.” *Journal of Mechanical Design*, **134**(9), p. 94503. 10, 11
- [62] DeVoil, P., Rossing, W. A. H., and Hammer, G. L., 2006. “Exploring profit–sustainability trade-offs in cropping systems using evolutionary algorithms.” *Environmental Modelling & Software*, **21**(9), pp. 1368–1374. 10, 11
- [63] You, F., Tao, L., Graziano, D. J., and Snyder, S. W., 2012. “Optimal design of sustainable cellulosic biofuel supply chains: Multiobjective optimization coupled with life cycle assessment and input–output analysis.” *AIChE Journal*, **58**(4), pp. 1157–1180. 10, 11
- [64] McPhee, J., and Yeh, W. W.-G., 2004. “Multiobjective optimization for sustainable groundwater management in semiarid regions.” *Journal of Water Resources Planning and Management*, **130**(6), pp. 490–497. 10, 11
- [65] Byggeth, S., and Hochschorner, E., 2006. “Handling trade-offs in ecodesign tools for sustainable product development and procurement.” *Journal of Cleaner Production*, **14**(15), pp. 1420–1430. 10
- [66] Pohekar, S. D., and Ramachandran, M., 2004. “Application of multi-criteria decision making to sustainable energy planning – A review.” *Renewable and Sustainable Energy Reviews*, **8**(4), pp. 365–381. 10, 11
- [67] Fitzgerald, D. P., Herrmann, J. W., and Schmidt, L. C., 2010. “A conceptual design tool for resolving conflicts between product functionality and environmental impact.” *Journal of Mechanical Design*, **132**(9), p. 91006. 10

- [68] Mala-Jetmarova, H., Barton, A., and Bagirov, A., 2014. “Exploration of the Trade-Offs between Water Quality and Pumping Costs in Optimal Operation of Regional Multiquality Water Distribution Systems.” *Journal of Water Resources Planning and Management*. 10
- [69] Michalek, J. J., Chester, M., Jaramillo, P., Samaras, C., Shiau, C.-S. N., and Lave, L. B., 2011. “Valuation of plug-in vehicle life-cycle air emissions and oil displacement benefits.” *Proceedings of the National Academy of Sciences*, **108**(40), pp. 16554–16558. 10, 11
- [70] Alfaris, A., Siddiqi, A., Rizk, C., de Weck, O., and Svetinovic, D., 2010. “Hierarchical decomposition and multidomain formulation for the design of complex sustainable systems.” *Journal of Mechanical Design*, **132**(9), p. 91003. 11
- [71] Thurston, D. L., and Srinivasan, S., 2003. “Constrained optimization for green engineering decision-making.” *Environmental science & technology*, **37**(23), pp. 5389–5397. 11
- [72] Cortés-Borda, D., Guillén-Gosálbez, G., and Esteller, L. J., 2013. “On the use of weighting in {LCA}: translating decision makers’ preferences into weights via linear programming.” *The International Journal of Life Cycle Assessment*, **18**(5), pp. 948–957. 11
- [73] Michalek, J. J., Papalambros, P. Y., and Skerlos, S. J., 2004. “A study of fuel efficiency and emission policy impact on optimal vehicle design decisions.” *Ann Arbor*, **1001**, p. 48109. 11
- [74] Whitefoot, K., Fowlie, M., and Skerlos, S., 2011. “Product design response to industrial policy: Evaluating fuel economy standards using an engineering model of endogenous product design.” *Energy Institute at Haas Working Paper No. WP-214*. 11
- [75] Rossing, W. A. H., Jansma, J. E., De Ruijter, F. J., and Schans, J., 1997. “Operationalizing sustainability: exploring options for environmentally friendly flower bulb production systems.” *European Journal of Plant Pathology*, **103**(3), pp. 217–234. 11
- [76] Mattson, C. A., Lofthouse, V., Bhamra, T., Pack, A. T., Lofthouse, V., and Bhamra, T., 2015. “Exploring Decision Tradeoffs in Sustainable Design.” In *AMSE 2015 International Design Engineering Technical Conference*, pp. 1–14. 12, 13
- [77] Clark, G., Kosoris, J., Hong, L. N., and Crul, M., 2009. “Design for sustainability: current trends in sustainable product design and development.” *Sustainability*, **1**(3), pp. 409–424. 13
- [78] She, J., and MacDonald, E., 2014. “Priming Designers to Communicate Sustainability.” *Journal of Mechanical Design*, **136**(1), pp. 1–12. 14
- [79] Kishita, Y., Low, B. H., Fukushige, S., Umeda, Y., Suzuki, A., and Kawabe, T., 2010. “Checklist-based assessment methodology for sustainable design.” *Journal of Mechanical Design*, **132**(9), p. 91011. 16
- [80] Zhu, Z., Wang, K., and Zhang, B., 2014. “Applying a network data envelopment analysis model to quantify the eco-efficiency of products: a case study of pesticides.” *Journal of cleaner production*, **69**, pp. 67–73. 16

- [81] Hauschild, M. Z., 2015. "Better—but is it good enough? On the need to consider both eco-efficiency and eco-effectiveness to gauge industrial sustainability." *Procedia CIRP*, **29**, pp. 1–7. 16
- [82] ISO, 2013. ISO/TS 14067:2013 Greenhouse gasses - Carbon footprint of products - Requirements and guidelines for quantification and communication Tech. rep., International Standard Organization, (ISO). 26
- [83] EPA, 2011. AP 42, Fifth Edition: Compilation of Air Pollutant Emission Factors, Volume 1: Stationary Point and Area Sources Tech. rep., Environmental Protection Agency (EPA). 26
- [84] Malewicki, D., 1983. "New Unified Performance Graphs and Comparisons for Streamlined Human-Powered Vehicles." In *2nd Human-Powered-Vehicle Scientific Symposium, IHPVA*. 29
- [85] Grabowski, M., Merrick, J. R. W., Harrold, J. R., Massuchi, T. A., and van Dorp, J. D., 2000. "Risk modeling in distributed, large-scale systems." *Systems, Man and Cybernetics, Part A: Systems and Humans, IEEE Transactions on*, **30**(6), pp. 651–660. 30
- [86] Baker, S. P., O'Neill, B., Haddon, W., and Long, W. B., 1974. "THE INJURY SEVERITY SCORE: A METHOD FOR DESCRIBING PATIENTS WITH MULTIPLE INJURIES AND EVALUATING EMERGENCY CARE." *The Journal of trauma*, **14**(No3), pp. 187–196. 30
- [87] Esteves, A. M., Franks, D., and Vanclay, F., 2012. "Social impact assessment: the state of the art." *Impact Assessment & Project Appraisal*, **30**(1), pp. 34–42. 46, 65
- [88] Freudenburg, W. R., 1986. "Social impact assessment." *Annual review of sociology*, pp. 451–478. 46
- [89] Benoît, C., Norris, G. A., Valdivia, S., Citroth, A., Moberg, A., Bos, U., Prakash, S., Ugaya, C., and Beck, T., 2010. "The guidelines for social life cycle assessment of products: just in time!" *The international journal of life cycle assessment*, **15**(2), pp. 156–163. 47
- [90] Jørgensen, A., Bocq, A. L., Nazarkina, L., Hauschild, M., Le Bocq, A., Nazarkina, L., and Hauschild, M., 2008. "Methodologies for Social Life Cycle Assessment." *International Journal of Life Cycle Assessment*, **13**(2), pp. 96–103. 47, 65
- [91] Van Den Ende, J., Mulder, K., Knot, M., Moors, E., and Vergragt, P., 1998. "Traditional and modern technology assessment: toward a toolkit." *Technological Forecasting and Social Change*, **58**(1-2), pp. 5–21. 48
- [92] Williams, R., and Edge, D., 1996. "The social shaping of technology." *Research policy*, **25**(6), pp. 865–899. 48
- [93] Russell, A. W., Vanclay, F. M., and Aslin, H. J., 2010. "Technology assessment in social context: The case for a new framework for assessing and shaping technological developments." *Impact Assessment and Project Appraisal*, **28**(2), pp. 109–116. 48

- [94] Rolfe, J., Petkova, V., Lockie, S., and Ivanova, G., 2007. "Mining impacts and the development of the Moranbah township." *Canberra: Australian National University*. 51
- [95] Esteves, A. M., 2008. "Mining and social development: Refocusing community investment using multi-criteria decision analysis." *Resources Policy*, **33**(1), pp. 39–47. 51
- [96] Lockie, S., Franettovich, M., Petkova-Timmer, V., Rolfe, J., and Ivanova, G., 2009. "Coal mining and the resource community cycle: a longitudinal assessment of the social impacts of the Coppabella coal mine." *Environmental Impact Assessment Review*, **29**(5), pp. 330–339. 51
- [97] Petkova, V., Lockie, S., Rolfe, J., and Ivanova, G., 2009. "Mining developments and social impacts on communities: Bowen Basin case studies." *Rural Society*, **19**(3), pp. 211–228. 51, 58
- [98] Forsey, M., 2011. "Living on edges: Supplementing education in an Australian mining town." *International Institute for Asian Studies Newsletter*, **56**(Spring), pp. 21–23. 51
- [99] Hajkowicz, S. A., Heyenga, S., and Moffat, K., 2011. "The relationship between mining and socio-economic well being in Australia's regions." *Resources Policy*, **36**(1), pp. 30–38. 51
- [100] Brouwer, R., and Van Ek, R., 2004. "Integrated ecological, economic and social impact assessment of alternative flood control policies in the Netherlands." *Ecological economics*, **50**(1-2), pp. 1–21. 51, 56
- [101] Pfeffer, M. J., 1983. "Social origins of three systems of farm production in the United States." *Rural Sociology*, **48**(4), p. 540. 51
- [102] Holland, K. M., 2007. "A history of Chinese immigration in the United States and Canada." *American Review of Canadian Studies*, **37**(2), pp. 150–160. 51
- [103] Hudson, J. C., 1982. "Towns of the western railroads." *Great Plains Quarterly*, **2**(1), pp. 41–54. 51, 58
- [104] Walters Jr, W. D., 2001. "Town Site Evolution in Southwestern Michigan 1830-1869." *Journal of Cultural Geography*, **19**(1), pp. 23–52. 51
- [105] Hafen, T. K., 1997. "City of saints, city of sinners: the development of Salt Lake City as a tourist attraction 1869–1900." *Western historical quarterly*, **28**(3), pp. 342–378. 51, 60
- [106] Mayda, C., 2011. "The booms and busts of Noonan, North Dakota." *FOCUS on Geography*, **54**(4), p. 152. 51
- [107] Castaing Gachassin, M., 2013. "Should I stay or should I go? The role of roads in migration decisions." *Journal of African Economies*, **22**(5), pp. 796–826. 51
- [108] Rudel, T. K., and Richards, S., 1990. "Urbanization, roads, and rural population change in the Ecuadorian Andes." *Studies in Comparative International Development*, **25**(3), pp. 73–89. 51

- [109] Petrova, S., and Marinova, D., 2015. "Using soft' and hard' social impact indicators to understand societal change caused by mining: a Western Australia case study." *Impact Assessment and Project Appraisal*, **33**(1), pp. 16–27. 51, 56, 58, 59
- [110] Mauthner, N. S., Maclean, C., and McKee, L., 2000. "My dad hangs out of helicopter doors and takes pictures of oil platforms': Children's accounts of parental work in the oil and gas industry." *Community, Work & Family*, **3**(2), pp. 133–162. 52
- [111] Parkes, K. R., Carnell, S. C., and Farmer, E. L., 2005. "Living two lives' Perceptions, attitudes and experiences of spouses of UK offshore workers." *Community, Work and Family*, **8**(4), pp. 413–437. 52
- [112] COWAN, R. S., 1976. "The' industrial revolution" in the home: Household technology and social change in the 20th century." *Technology and Culture*, **17**(1), pp. 1–23. 52, 53, 56
- [113] Thrall, C. A., 1982. "The conservative use of modern household technology." *Technology and Culture*, **23**(2), pp. 175–194. 52, 53
- [114] Gershuny, J., and Harms, T. A., 2016. "Housework now takes much less time: 85 years of us rural women's time use." *Social Forces*, pp. 1–22. 52, 53
- [115] Weisskirch, R. S., 2011. "No crossed wires: Cell phone communication in parent-adolescent relationships." *Cyberpsychology, Behavior, and Social Networking*, **14**(7-8), pp. 447–451. 52
- [116] Ames, M. G., Go, J., Kaye, J., and Spasojevic, M., 2010. "Making love in the network closet: the benefits and work of family videochat." In *Proceedings of the 2010 ACM conference on Computer supported cooperative work*, ACM, pp. 145–154. 52
- [117] Horst, H. A., 2006. "The blessings and burdens of communication: cell phones in Jamaican transnational social fields." *Global Networks*, **6**(2), pp. 143–159. 53
- [118] Donner, J., 2006. "The use of mobile phones by microentrepreneurs in Kigali, Rwanda: Changes to social and business networks." *Information Technologies & International Development*, **3**(2), pp. pp—3. 53
- [119] Wei, R., and Lo, V.-H., 2006. "Staying connected while on the move: Cell phone use and social connectedness." *New Media & Society*, **8**(1), pp. 53–72. 53
- [120] Donner, J., 2009. "Blurring livelihoods and lives: The social uses of mobile phones and socioeconomic development." *Innovations: Technology, Governance, Globalization*, **4**(1), pp. 91–101. 53, 55, 58
- [121] Boonmongkon, P., Ojanen, T. T., Samakkeekarom, R., Samoh, N., Iamsilpa, R., Topananan, S., Cholratana, M., and Guadamuz, T. E., 2013. "She met her (boy) friend online': negotiating gender identity and sexuality among young Thai women in online space." *Culture, health & sexuality*, **15**(10), pp. 1162–1174. 53
- [122] Garton, L., and Wellman, B., 1995. "Social impacts of electronic mail in organizations: A review of the research literature." *Annals of the International Communication Association*, **18**(1), pp. 434–453. 53, 58, 59

- [123] Turco, C. J., 2016. *The conversational firm: Rethinking bureaucracy in the age of social media*. Columbia University Press. 53
- [124] Wu, Z., and MacNeill, L., 2002. "Education, work, and childbearing after age 30." *Journal of Comparative Family Studies*, pp. 191–213. 53
- [125] Friese, C., Becker, G., and Nachtigall, R. D., 2008. "Older motherhood and the changing life course in the era of assisted reproductive technologies." *Journal of Aging Studies*, **22**(1), pp. 65–73. 53, 54
- [126] Mathews, T. J., and Hamilton, B. E., 2009. "Delayed childbearing; more women are having their first child later in life." 53
- [127] Mathews, T. J., and Hamilton, B. E., 2014. "First births to older women continue to rise." 53
- [128] Shah, N., 2011. "Special education pupils find learning tool in iPad applications.." *Education week*, **30**(22), pp. 1–16. 54
- [129] Haluck, R. S., and Krummel, T. M., 2000. "Computers and virtual reality for surgical education in the 21st century." *Archives of surgery*, **135**(7), pp. 786–792. 54
- [130] Raffle, H., Ballagas, R., Revelle, G., Horii, H., Follmer, S., Go, J., Reardon, E., Mori, K., Kaye, J., and Spasojevic, M., 2010. "Family story play: reading with young children (and elmo) over a distance." In *Proceedings of the SIGCHI Conference on Human Factors in Computing Systems*, ACM, pp. 1583–1592. 54
- [131] Nimkoff, M. F., 1950. "What Do Modern Inventions Do to Family Life?." *The ANNALS of the American Academy of Political and Social Science*, **272**(1), pp. 53–58. 55, 56
- [132] Faler, P., 1974. "Cultural aspects of the industrial revolution: Lynn, Massachusetts, shoemakers and industrial morality, 1826–1860." *Labor History*, **15**(3), pp. 367–394. 55
- [133] Bray, F., 1978. "Swords into plowshares: a study of agricultural technology and society in early China." *Technology and Culture*, **19**(1), pp. 1–31. 55, 56
- [134] Cudahy, B. J., 2006. *Box boats: How container ships changed the world*. Fordham Univ Press. 55, 56
- [135] der Voort, N., and Vanclay, F., 2015. "Social impacts of earthquakes caused by gas extraction in the Province of Groningen, The Netherlands." *Environmental Impact Assessment Review*, **50**, pp. 1–15. 55
- [136] Okeagu, J. E., Okeagu, J. C., Adegoke, A. O., and Onuoha, C. N., 2006. "The environmental and social impact of petroleum and natural gas exploitation in Nigeria." *Journal of Global South Studies*, **23**(1), p. 199. 55, 56, 58
- [137] Chesley, N., Siibak, A., and Wajcman, J., 2013. "13. Information and communication technology use and work–life integration1." *Handbook of Work-Life Integration Among Professionals: Challenges and Opportunities*, p. 245. 55

- [138] Chesley, N., and Johnson, B. E., 2015. "Technology use and the new economy: Work extension, network connectivity, and employee distress and productivity." In *Work and Family in the New Economy*. Emerald Group Publishing Limited, pp. 61–99. 55
- [139] Milkman, R., and Pullman, C., 1991. "Technological change in an auto assembly plant: The impact on workers' tasks and skills." *Work and Occupations*, **18**(2), pp. 123–147. 55
- [140] Berman, E., Bound, J., and Machin, S., 1998. "Implications of skill-biased technological change: international evidence." *The quarterly journal of economics*, **113**(4), pp. 1245–1279. 55
- [141] Brynjolfsson, E., and McAfee, A., 2014. *The second machine age: Work, progress, and prosperity in a time of brilliant technologies*. WW Norton & Company. 55
- [142] Guyatt, M., 2001. "Better legs: artificial limbs for British veterans of the First World War." *Journal of Design History*, **14**(4), pp. 307–325. 55, 57
- [143] Grusky, D. B., and Weisshaar, K. R., 2014. *Social Stratification: Class, Race, and Gender in Sociological Perspective*. 55
- [144] Parikh, A., and Thorbecke, E., 1996. "Impact of rural industrialization on village life and economy: a social accounting matrix approach." *Economic development and cultural change*, **44**(2), pp. 351–377. 56
- [145] Wheatley, M. A., 1997. "Social and cultural impacts of mercury pollution on aboriginal peoples in Canada." *Water, Air, and Soil Pollution*, **97**(1-2), pp. 85–90. 56, 58, 59
- [146] Cuthill, M., 2010. "Strengthening the social in sustainable development: Developing a conceptual framework for social sustainability in a rapid urban growth region in Australia." *Sustainable Development*, **18**(6), pp. 362–373. 56
- [147] Weingaertner, C., and Moberg, Å., 2014. "Exploring social sustainability: Learning from perspectives on urban development and companies and products." *Sustainable Development*, **22**(2), pp. 122–133. 56, 57
- [148] Veblen, T., 2005. *Conspicuous consumption.*, Vol. 38 Penguin UK. 56
- [149] Solomon, M. R., 1983. "The role of products as social stimuli: A symbolic interactionism perspective." *Journal of Consumer research*, **10**(3), pp. 319–329. 56
- [150] Fussell, P., 1983. "Class: A Guide Through the American Status System Touchstone." 56
- [151] Grad, F. P., 2002. "The preamble of the constitution of the World Health Organization." *Bulletin of the World Health Organization*, **80**, p. 981. 56
- [152] Haans, A., and De Kort, Y. A. W., 2012. "Light distribution in dynamic street lighting: Two experimental studies on its effects on perceived safety, prospect, concealment, and escape." *Journal of Environmental Psychology*, **32**(4), pp. 342–352. 56
- [153] Islam, S., Makris, A., and Bergeron, D., 2000. "The Spider Boot: An Effective Foot Protection System Against Anti-Personnel Mine Blasts." *Journal of Conventional Weapons Destruction*, **4**(2), p. 7. 56

- [154] Strayer, D. L., Drews, F. A., and Johnston, W. A., 2003. "Cell phone-induced failures of visual attention during simulated driving.." *Journal of experimental psychology: Applied*, **9**(1), p. 23. 56
- [155] Lesch, M. F., and Hancock, P. A., 2004. "Driving performance during concurrent cell-phone use: are drivers aware of their performance decrements?." *Accident Analysis & Prevention*, **36**(3), pp. 471–480. 56
- [156] Beede, K. E., and Kass, S. J., 2006. "Engrossed in conversation: The impact of cell phones on simulated driving performance." *Accident Analysis & Prevention*, **38**(2), pp. 415–421. 56
- [157] Strayer, D. L., Drews, F. A., and Crouch, D. J., 2006. "A comparison of the cell phone driver and the drunk driver." *Human factors*, **48**(2), pp. 381–391. 56
- [158] Fitch, G. M., Soccolich, S. A., Guo, F., McClafferty, J., Fang, Y., Olson, R. L., Perez, M. A., Hanowski, R. J., Hankey, J. M., and Dingus, T. A., 2013. The impact of hand-held and hands-free cell phone use on driving performance and safety-critical event risk Tech. rep. 56
- [159] Breed, A. L., and Ibler, I., 1982. "The motorized wheelchair: new freedom, new responsibility and new problems." *Developmental Medicine & Child Neurology*, **24**(4), pp. 366–371. 56, 57
- [160] Jordan, P. W., 1998. "Human factors for pleasure in product use." *Applied ergonomics*, **29**(1), pp. 25–33. 57
- [161] What are human rights? <https://www.ohchr.org/EN/Issues/Pages/WhatareHumanRights.aspx> Accessed: 2019-03-04. 57
- [162] Pierce, L. L., 1998. "Barriers to access: Frustrations of people who use a wheelchair for full-time mobility." *Rehabilitation Nursing*, **23**(3), pp. 120–125. 57
- [163] Meyers, A. R., Anderson, J. J., Miller, D. R., Shipp, K., and Hoenig, H., 2002. "Barriers, facilitators, and access for wheelchair users: substantive and methodologic lessons from a pilot study of environmental effects." *Social science & medicine*, **55**(8), pp. 1435–1446. 57
- [164] Rimmer, J. H., Riley, B., Wang, E., Rauworth, A., and Jurkowski, J., 2004. "Physical activity participation among persons with disabilities: barriers and facilitators." *American journal of preventive medicine*, **26**(5), pp. 419–425. 57
- [165] Bennett, S., Lee Kirby, R., Bennett, S., Lee Kirby, R., and Macdonald, B., 2009. "Wheelchair accessibility: descriptive survey of curb ramps in an urban area." *Disability and Rehabilitation: Assistive Technology*, **4**(1), pp. 17–23. 57
- [166] Zidarov, D., Swaine, B., and Gauthier-Gagnon, C., 2009. "Life habits and prosthetic profile of persons with lower-limb amputation during rehabilitation and at 3-month follow-up." *Archives of physical medicine and rehabilitation*, **90**(11), pp. 1953–1959. 57
- [167] Strickland, R., 1985. "Genocide-at-Law: An Historic and Contemporary View of the Native American Experience." *U. Kan. L. Rev.*, **34**, p. 713. 57

- [168] Hampton, K., and Wellman, B., 2003. "Neighboring in Netville: How the Internet supports community and social capital in a wired suburb." *City & Community*, **2**(4), pp. 277–311. 58
- [169] Dietz-Uhler, B., and Bishop-Clark, C., 2001. "The use of computer-mediated communication to enhance subsequent face-to-face discussions." *Computers in Human Behavior*, **17**(3), pp. 269–283. 58
- [170] Neustaedter, C., and Greenberg, S., 2012. "Intimacy in long-distance relationships over video chat." In *Proceedings of the SIGCHI Conference on Human Factors in Computing Systems*, ACM, pp. 753–762. 58
- [171] Goode, E., 1997. *Deviant behavior.*, 5th ed. Prentice Hall. 58
- [172] Schmallegger, F., 2005. *Criminal justice today: an introductory text for the 21st century.* Pearson Prentice Hall, Upper Saddle River (NJ). 58
- [173] Hoffmann, J. P., 2011. *Delinquency theories: Appraisals and applications.* Routledge. 59
- [174] Casteel, C., and Peek-Asa, C., 2000. "Effectiveness of crime prevention through environmental design (CPTED) in reducing robberies." *American journal of preventive medicine*, **18**(4), pp. 99–115. 59
- [175] Welsh, B. C., and Farrington, D. P., 2004. "Surveillance for crime prevention in public space: Results and policy choices in Britain and America." *Criminology & Public Policy*, **3**(3), pp. 497–526. 59
- [176] Cozens, P. M., Saville, G., and Hillier, D., 2005. "Crime prevention through environmental design (CPTED): a review and modern bibliography." *Property management*, **23**(5), pp. 328–356. 59
- [177] Welsh, B. C., and Farrington, D. P., 2009. "Public area CCTV and crime prevention: an updated systematic review and meta-analysis." *Justice Quarterly*, **26**(4), pp. 716–745. 59
- [178] Ratcliffe, J. H., Taniguchi, T., and Taylor, R. B., 2009. "The crime reduction effects of public CCTV cameras: a multi-method spatial approach." *Justice Quarterly*, **26**(4), pp. 746–770. 59
- [179] Herbert, D., and Davidson, N., 1994. "Modifying the built environment: the impact of improved street lighting." *Geoforum*, **25**(3), pp. 339–350. 59
- [180] Painter, K., 1996. "The influence of street lighting improvements on crime, fear and pedestrian street use, after dark." *Landscape and urban planning*, **35**(2-3), pp. 193–201. 59
- [181] Farrington, D. P., and Welsh, B. C., 2002. "Improved street lighting and crime prevention." *Justice Quarterly*, **19**(2), pp. 313–342. 59
- [182] Nzeadibe, T. C., Ajaero, C. K., Okonkwo, E. E., Okpoko, P. U., Akukwe, T. I., and Njoku-Tony, R. F., 2015. "Integrating community perceptions and cultural diversity in social impact assessment in Nigeria." *Environmental Impact Assessment Review*, **55**, pp. 74–83. 59

- [183] Colantonio, A., Dixon, T., Ganser, R., Carpenter, J., and Ngombe, A., 2009. “Measuring Socially Sustainable Urban Regeneration in Europe.” 59
- [184] Gramling, R., and Freudenburg, W. R., 1992. “Opportunity-Threat, Development, and Adaptation: Toward a Comprehensive Framework for Social Impact Assessment 1.” *Rural Sociology*, **57**(2), pp. 216–234. 59
- [185] Smits, D. D., 1994. “The frontier army and the destruction of the buffalo: 1865-1883.” *Western Historical Quarterly*, **25**(3), pp. 312–338. 60
- [186] Yastikli, N., 2007. “Documentation of cultural heritage using digital photogrammetry and laser scanning.” *Journal of Cultural Heritage*, **8**(4), pp. 423–427. 60
- [187] Rüther, H., Chazan, M., Schroeder, R., Neeser, R., Held, C., Walker, S. J., Matmon, A., and Horwitz, L. K., 2009. “Laser scanning for conservation and research of African cultural heritage sites: the case study of Wonderwerk Cave, South Africa.” *Journal of Archaeological Science*, **36**(9), pp. 1847–1856. 60
- [188] Vanclay, F., 2010. “The triple bottom line and impact assessment: how do TBL, EIA, SIA, SEA and EMS relate to each other?.” In *Tools, Techniques And Approaches For Sustainability: Collected Writings in Environmental Assessment Policy and Management*. World Scientific, pp. 101–124. 61, 83
- [189] Kirkpatrick, C., and Lee, N., 1999. “Integrated appraisal and decision-making.” *Environmental Impact Assessment Review*, **19**(3), pp. 227–232. 61, 83
- [190] Kidd, S., and Fischer, T. B., 2007. “Towards sustainability: is integrated appraisal a step in the right direction?.” *Environment and Planning C: Government and Policy*, **25**(2), pp. 233–249. 61, 84
- [191] Tajima, R., and Fischer, T. B., 2013. “Should different impact assessment instruments be integrated? Evidence from English spatial planning.” *Environmental Impact Assessment Review*, **41**, pp. 29–37. 61, 84
- [192] Alwi, S. R. W., Manan, Z. A., Klemeš, J. J., and Huisingh, D., 2014. Sustainability engineering for the future. 63
- [193] Younesi, M., and Roghanian, E., 2015. “A framework for sustainable product design: A hybrid fuzzy approach based on Quality Function Deployment for Environment.” *Journal of Cleaner Production*, **108**, pp. 385–394. 63
- [194] Lankenau, G. F. D., and Winter, A. G., 2019. “An engineering review of the farm tractor’s evolution to a dominant design.” *Journal of Mechanical Design*, **141**(3), p. 031107. 63
- [195] Rainock, M., Everett, D., Pack, A., Dahlin, E. C., and Mattson, C. A., 2018. “The social impacts of products: a review.” *Impact Assessment and Project Appraisal*, pp. 1–12. 64, 66, 70, 72, 75
- [196] Ottosson, H., Hirschi, E., Mattson, C. A., and Dahlin, E., 2017. “A Simple Starting Point for Designing for and/or Assessing the Social Impact of Products.” In *ASME 2017 International Design Engineering Technical Conferences and Computers and Information in*

Engineering Conference, American Society of Mechanical Engineers, pp. V02BT03A015—
-V02BT03A015. 64

- [197] Mattson, C. A., and Wood, A. E., 2014. “Nine principles for design for the developing world as derived from the engineering literature.” *Journal of Mechanical Design*, **136**(12), p. 121403. 64
- [198] Judge, B. M., Hölttä-Otto, K., and Winter, A. G., 2015. “Developing world users as lead users: a case study in engineering reverse innovation.” *Journal of Mechanical Design*, **137**(7), p. 071406. 65
- [199] Mahmoudi, H., Renn, O., Vanclay, F., Hoffmann, V., and Karami, E., 2013. “A framework for combining social impact assessment and risk assessment.” *Environmental Impact Assessment Review*, **43**, pp. 1–8. 65
- [200] UNEP Setac Life Cycle Initiative, 2009. *Guidelines for Social Life Cycle Assessment of Products.*, Vol. 15. 65
- [201] Siebert, A., Bezama, A., O’Keeffe, S., Thrän, D., Keffe, S. O., and Thrän, D., 2016. “Social life cycle assessment: in pursuit of a framework for assessing wood-based products from bioeconomy regions in Germany.” *International Journal of Life Cycle Assessment*, pp. 1–12. 65
- [202] Gmelin, H., and Seuring, S., 2014. “Determinants of a sustainable new product development.” *Journal of Cleaner production*, **69**, pp. 1–9. 65
- [203] Chhipi-Shrestha, G. K., Hewage, K., and Sadiq, R., 2015. “‘Socializing’ sustainability: a critical review on current development status of social life cycle impact assessment method.” *Clean Technologies and Environmental Policy*, **17**(3), pp. 579–596. 65
- [204] Ma, J., and Kremer, G. E. O., 2015. “A Modular Product Design Method to Improve Product Social Sustainability Performance.” In *ASME 2015 International Design Engineering Technical Conferences and Computers and Information in Engineering Conference*, American Society of Mechanical Engineers, pp. V004T05A053—V004T05A053. 65
- [205] Svensson, M., and Gould, R., 2015. “Hurdles to Clear: Cognitive Barriers in Sustainable Product Development.” In *The 23rd Nordic Academy of Management Conference*, Copenhagen. 65
- [206] Alsaffar, A. J., Raoufi, K., Kim, K.-Y., Kremer, G. E. O., and Haapala, K. R., 2016. “Simultaneous consideration of unit manufacturing processes and supply chain activities for reduction of product environmental and social impacts.” *Journal of Manufacturing Science and Engineering*, **138**(10), p. 101009. 65
- [207] Fuge, M., and Agogino, A., 2015. “Pattern analysis of ideo’s human-centered design methods in developing regions.” *Journal of Mechanical Design*, **137**(7), p. 071405. 65
- [208] Ahmad, S., Wong, K. Y., Tseng, M. L., and Wong, W. P., 2018. “Sustainable product design and development: A review of tools, applications and resesarch prospects.” *Resources, Conservation & Recycling*. 65

- [209] Schögl, J.-P., Baumgartner, R. J., and Hofer, D., 2017. “Improving sustainability performance in early phases of product design: A checklist for sustainable product development tested in the automotive industry.” *Journal of Cleaner Production*, **140**, pp. 1602–1617. 65
- [210] Mattson, C. A., Pack, A. T., Lofthouse, V., and Bhamra, T., 2019. “Using a Product’s Sustainability Space as a Design Exploration Tool.” *Design Science*, **5**, pp. 1–34. 65
- [211] Wood, A. E., and Mattson, C. A., 2019. “Quantifying the effects of various factors on the utility of design ethnography in the developing world.” *Research in Engineering Design*, pp. 1–22. 65
- [212] Chen, C.-H., Khoo, L. P., and Yan, W., 2003. “Evaluation of multicultural factors from elicited customer requirements for new product development.” *Research in Engineering Design*, **14**(3), pp. 119–130. 66
- [213] Garay, L., and Font, X., 2012. “Doing good to do well? Corporate social responsibility reasons, practices and impacts in small and medium accommodation enterprises.” *International Journal of Hospitality Management*, **31**(2), pp. 329–337. 66
- [214] Kalish, D., Burek, S., Costello, A., Schwartz, L., and Taylor, J., 2018. “Integrating Sustainability into New Product Development: Available tools and frameworks can help companies ensure that sustainability is embedded as a fundamental building block of new product development.” *Research Technology Management*, **61**(2), pp. 37–46. 66
- [215] Rapley, T. J., 2001. “The art (fulness) of open-ended interviewing: some considerations on analysing interviews.” *Qualitative research*, **1**(3), pp. 303–323. 68
- [216] Emmel, N., 2013. *Sampling and choosing cases in qualitative research: A realist approach*. Sage. 68
- [217] Suri, H., 2011. “Purposeful sampling in qualitative research synthesis.” *Qualitative Research Journal*, **11**(2), pp. 63–75. 68
- [218] Luker, K., 2008. *Salsa dancing into the social sciences*. Harvard University Press. 69
- [219] Fereday, J., and Muir-Cochrane, E., 2006. “Demonstrating rigor using thematic analysis: A hybrid approach of inductive and deductive coding and theme development.” *International journal of qualitative methods*, **5**(1), pp. 80–92. 70
- [220] Charmaz, K., 2014. *Constructing grounded theory*. Sage. 70
- [221] Monette, D. R., Sullivan, T. J., and DeJong, C. R., 2013. *Applied social research: A tool for the human services*. Cengage Learning. 70
- [222] Attride-Stirling, J., 2001. “Thematic networks: an analytic tool for qualitative research.” *Qualitative research*, **1**(3), pp. 385–405. 71
- [223] Teng, S.-H., and Ho, S.-Y., 1996. “Failure mode and effects analysis: an integrated approach for product design and process control.” *International journal of quality & reliability management*, **13**(5), pp. 8–26. 77

APPENDIX A. INTERVIEW GUIDE FOR INDUSTRY PROFESSIONALS

A.1 Interview Guide

Introductory Questions:

1. What is your official job title?
2. How long have you worked for this company?
3. How many employees does this company have?
4. How long has this company been in business?
5. What experiences have you had in design and product development?
6. Please describe your company's products and functions.
7. For whom or what industry are the products designed?

A.2 Research Questions

Prompt: Within design there is a principle called sustainable design. The three major factors in sustainable design are economic, environmental, and social sustainability. Our study is focusing on the social aspect of sustainability and specifically the social impacts of engineered products. Social impact refers to the effect that an engineered product has on the 'day-to-day quality of life of persons or communities'. For example, a smart phone may have an impact on the education of an individual, or the social dynamic of a family. The following discussion will center around the social impacts of this company's products.

It will also be helpful to clarify that, at least to begin with, we will not be considering social impacts throughout the supply chain of a given product. This may come up in later studies, but not at this time we wish to only consider impacts during a product's use stage.

1. Does your company have any processes in place to consider the social impact of a product?
If so, what are they?
 - How often are these processes followed? (Every time, most of the time, rarely)
 - What impacts do you hope your products have on your users?
2. We have developed a list of potential social impacts (see next page) a product may have. Which of these social factors, or others, do you consider?
 - How do you ensure you are considering all possible factors?
3. For the impacts you identified, what measures do you use to evaluate that you have had the impact you desired?
 - How efficient are the processes described previously at ensuring the desired impact is achieved?
 - How do you mitigate unintended consequences?
4. Taking another look at our list of potential impacts (next page) a product may have, it is also possible that the existing conditions of a community or end user in regards to these impact areas will affect how well a product is adopted or how effectively it serves its intended purpose. How do these factors influence how you design for a specific end user and/or community?
5. What government regulations dictate the way in which your products are designed?
 - True or false: Formal design processes and regulations only consider impacts that have a direct health and safety impact?
6. What is the greatest value in considering the social impacts of your products?
7. What are the biggest barriers to being able to design with social impact in mind?

Table A.1: Social impacts of products as found in chapter 3 and used in each interview

Population Change	Family	Gender	Education
In/out migration; transiency of the population	Alteration in family structure	Gender roles	Education and skills
Relocation of families	Family roles	Gender violence	Community empowerment and capacity building
Presence of seasonal/leisure population	Family's role in society	Gender stressors	Media and other access to information
Introduction of new work population	Family violence	Gender inequality	Product Specific Training
Age structure of the community	Family Stressors		
	Changing family ties		
Paid Work	Stratification	Health & Well-being	Human Rights
Increase/decrease job opportunities	Inequality between community and outside communities	Secure living conditions	Homeless rights
Industrial diversification/change of economic focus	Inequality within community	Safe living conditions	Disabled rights
Local business environment	Social status indicators	Safety and security (real and perceived)	Indigenous rights
Change in employment rates	Social mixing	Activity/exercise	Gender rights
Change in individual's employment status	Introduction of new classes or sub-communities (ex: gangs)	Personal Mental Health	Other minority rights
	Personal prestige	Personal Physical Health	Democracy or decision making participation
	Individual's goals and future opportunities	Morality	
		Personal life/health improvement from product	
		Individual's lingering feelings from usage (frustration, positivity, etc.)	
		Individual's perceived future opportunities/goals	
		Diet	
Networks & Communication	Conflict & Crime	Cultural Heritage & Identity	
Social capital	Potential conflicts	Weakening and strengthening of values	
Networks (relations between actors)	Homicide and violent crimes	Cultural/ethnic/religious ideas and beliefs	
Weakening or strengthening of relationships	Non-violent crimes	Cultural intolerance	
How communication is carried out	Corruption	Cultural/religious rites and practices	
Reliance on participation in the decision making process	Deviance from informal regulations/norms	Cultural/religious artifacts and places	
Relationships between community actors	Potential of assault or attack	Religious demographics	
Impaired or improved personal relationships	Increased or decreased substance abuse	Individual identity reliant on cultural identity	
	Individual noncompliance with rules	Understanding of the universe and the role one plays in it	